



RADIO TEST REPORT

Applicant: ZhenHui Electronic Technology (Dongguan) Co., Ltd

Address: Room 201, building 1, 101shutian road, humen town , dongguan city, guangdong province, China.

Manufacturer: ZhenHui Electronic Technology (Dongguan) Co., Ltd

Address: Room 201, building 1, 101shutian road, humen town , dongguan city, guangdong province, China.

EUT: Face Recognition Equipment

Brand Name: 
振汇通

Model Number: ZH-800T
ZH-800L, ZH-800G, ZH-800Q, ZH700L, ZH700G, ZH500, ZH350

Date of Receipt: Apr. 01, 2020

Test Date: Apr. 01, 2020 - Apr. 08, 2020

Date of Report: Apr. 08, 2020

Prepared By: Shenzhen DL Testing Technology Co., Ltd.

Address: Part One of 301, A-2 Factory Building, Yalijia Industrial Plant, No. 87, Hengping Road, Yuanshan Street, Longgang District, Shenzhen, China

Applicable Standards: ETSI EN 300 328 V2.2.2 (2019-07)

Test Result: Pass

Report Number: DL-2020040732R

Prepared by(Engineer): Alisa Song

Reviewer(Supervisor): Nico Zou

Approved(Manager): Jade Yang



This test report is based on a single evaluation of one sample of above mentioned products. It is not permitted to be duplicated in extracts without written approval of Shenzhen DL Testing Technology Co., Ltd.



TABLE OF CONTENT

Test Report Declaration	Page
1. VERSION.....	4
2. TEST SUMMARY.....	4
3. GENERAL INFORMATION.....	5
3.1 Description of Device (EUT).....	5
3.2 Tested System Details.....	12
3.3 Test Mode Description.....	12
3.4 Test Conditions.....	13
3.5 Test Uncertainty.....	13
4. TEST INSTRUMENT USED.....	14
5. RF OUTPUT POWER.....	15
5.1 Block Diagram Of Test Setup.....	15
5.2 Limit.....	15
5.3 Test Procedure.....	15
5.4 Test Result.....	16
6. POWER SPECTRAL DENSITY.....	17
6.1 Block Diagram of Test Setup.....	17
6.2 Test Standard and Limit.....	17
6.3 Test Procedure.....	17
6.4 Test Result.....	17
7. ADAPTIVITY.....	18
7.1 Block Diagram of Test Setup.....	18
7.2 Test Standard and Limit.....	18
7.3 Test Procedure.....	19
7.4 Test Result.....	19
8. OCCUPIED CHANNEL BANDWIDTH.....	29
8.1 Block Diagram of Test Setup.....	29
8.2 Test Standard and Limit.....	29
8.3 Test Procedure.....	29
8.4 Test Result.....	29
9. TRANSMITTER UNWANTED EMISSIONS IN THE OUT-OF-BAND DOMAIN.....	30
9.1 Block Diagram of Test Setup.....	30
9.2 Test Standard and Limit.....	30
9.3 Test Procedure.....	30
9.4 Test Result.....	31
10. TRANSMITTER UNWANTED EMISSIONS IN THE SPURIOUS DOMAIN.....	42
10.1 Block Diagram of Test Setup.....	42
10.2 Limit.....	43



10.3	Test Procedure	43
10.4	Test Result.....	43
11.	RECEIVER SPURIOUS EMISSIONS.....	46
11.1	Block Diagram of Test Setup	46
11.2	Limit.....	47
11.3	Test Procedure	47
11.4	Test Result.....	47
12.	RECEIVER BLOCKING.....	50
12.1	Block Diagram of Test Setup	50
12.2	Limit.....	50
12.3	Test Procedure	51
12.4	Test Results.....	51
13.	GEO-LOCATION CAPABILITY	52
13.1	Definition and Requirements	52
13.2	Test Results.....	52
14.	SETUP PHOTOGRAPHS.....	53
15.	EUT PHOTOGRAPHS	54



1. VERSION

Version No.	Date	Description
00	Apr. 08, 2020	Original

2. TEST SUMMARY

No	Test Item	Clause No	Result
Transmitter Parameters			
1	RF output power	4.3.2.2	PASS
2	Power Spectral Density	4.3.2.3	PASS
3	Duty Cycle, Tx-sequence, Tx-gap	4.3.2.4	N/A
4	Medium Utilisation (MU) factor	4.3.2.5	N/A
5	Adaptive non-FHSS using DAA	4.3.2.6	PASS
6	Occupied Channel Bandwidth	4.3.2.7	PASS
7	Transmitter unwanted emissions in the out-of-band domain	4.3.2.8	PASS
8	Transmitter unwanted emissions in the spurious domain	4.3.2.9	PASS
Receiver Parameters			
9	Receiver spurious emissions	4.3.2.10	PASS
10	Receiver Blocking	4.3.2.11	PASS
11	Geo-location capability	4.3.2.12	N/A
Note: (1) "N/A" denotes test is not applicable in this Test Report (2) Test Facility: Shenzhen DL Testing Technology Co., Ltd. Address: Part One of 301, A-2 Factory Building, Yalijia Industrial Plant, No. 87, Hengping Road, Yuanshan Street, Longgang District, Shenzhen, China			



3. GENERAL INFORMATION

3.1 Description of Device (EUT)

EUT: Face Recognition Equipment

Brand Name:  振汇通

Model Number: ZH-800T
ZH-800L, ZH-800G, ZH-800Q, ZH700L, ZH700G, ZH500, ZH350

Model difference: The product's different for model number and appearance color.

Power Supply: DC 12V from adapter
Model: JHD-AP024C-120200BA-A

Adapter: Input: AC 100-240V 50/60Hz 0.45A
Output: DC 12V  2000mA

Receiver category: 1

Operation Frequency: 802.11b/g/n20:2412~2472 MHz
802.11n40:2422~2462 MHz

Modulation Type: CCK/OFDM/DBPSK/DAPSK

Number Of Channel: 802.11b/g/n20:13CH
802.11n40:11 CH
802.11b:11/5.5/2/1 Mbps

Bit Rate of Transmitter: 802.11g:54/48/36/24/18/12/9/6Mbps
802.11n Up to 150Mbps

Antenna Type: Internal antenna*2

Antenna Gain: 2.0dBi

Hardware Version: ---

Software Version: ---

Firmware: ---

Note1: ZH-800T was selected as the test model and the data's have been recorded in this report.

2: For a more detailed features description, please refer to the manufacturer's specifications or the User's Manual.

Channel List for 802.11b/g/n HT20							
Channel	Frequency (MHz)	Channel	Frequency (MHz)	Channel	Frequency (MHz)	Channel	Frequency (MHz)
01	2412	05	2432	09	2452	13	2472
02	2417	06	2437	10	2457	/	/
03	2422	07	2442	11	2462	/	/
04	2427	08	2447	12	2467	/	/

Channel List for 802.11 n HT40							
Channel	Frequency (MHz)	Channel	Frequency (MHz)	Channel	Frequency (MHz)	Channel	Frequency (MHz)



03	2422	06	2437	09	2452	12	2467
04	2427	07	2442	10	2457	13	2472
05	2432	08	2447	11	2462	/	/

ANNEX E.2

a) The type of wideband data transmission equipment::

- FHSS
- non-FHSS

b) In case of FHSS:

- In case of non-Adaptive FHSS equipment:
The number of Hopping Frequencies:
- In case of Adaptive FHSS equipment:
The maximum number of Hopping Frequencies:
The minimum number of Hopping Frequencies:
- The (average) dwell time:

c) Adaptive / non-adaptive equipment:

- non-adaptive Equipment
- adaptive Equipment without the possibility to switch to a non-adaptive mode
- adaptive Equipment which can also operate in a non-adaptive mode

d) In case of adaptive equipment:

- The Channel Occupancy Time implemented by the equipment: ms
- The equipment has implemented an LBT mechanism
- In case of non-FHSS equipment:
 - The equipment is Frame Based equipment
 - The equipment is Load Based equipment
 - The equipment can switch dynamically between Frame Based and Load Based equipment
- The CCA time implemented by the equipment: μs
- The equipment has implemented a DAA mechanism
- The equipment can operate in more than one adaptive mode



e) In case of non-adaptive Equipment:

The maximum RF Output Power (e.i.r.p.): 8.58dBm

The maximum (corresponding) Duty Cycle: %

Equipment with dynamic behaviour, that behaviour is described here. (e.g. the different combinations of duty cycle and corresponding power levels to be declared):

f) The worst case operational mode for each of the following tests:

- RF Output Power
802.11b
- Power Spectral Density
802.11b
- Duty cycle, Tx-Sequence, Tx-gap
802.11b
- Accumulated Transmit time, Frequency Occupation & Hopping Sequence (only for FHSS equipment)
.....
- Hopping Frequency Separation (only for FHSS equipment)
.....
- Medium Utilisation
.....
- Adaptivity & Receiver Blocking
.....
- Nominal Channel Bandwidth
20/40MHz
- Transmitter unwanted emissions in the OOB domain
802.11b
- Transmitter unwanted emissions in the spurious domain
802.11b
- Receiver spurious emissions
802.11b

g) The different transmit operating modes (tick all that apply):

- Operating mode 1: Single Antenna Equipment
- Equipment with only one antenna
- Equipment with two diversity antennas but only one antenna active at any moment in time
- Smart Antenna Systems with two or more antennas, but operating in a (legacy) mode where only one antenna is used (e.g. IEEE 802.11™ legacy mode in smart antenna systems)
- Operating mode 2: Smart Antenna Systems - Multiple Antennas without beam forming



- Single spatial stream/Standard throughput/(e.g. IEEE 802.11™ legacy mode)
- High Throughput (> 1 spatial stream) using Nominal Channel Bandwidth 1
- High Throughput (> 1 spatial stream) using Nominal Channel Bandwidth 2

NOTE1: Add more lines if more channel bandwidths are supported.

- Operating mode 3: Smart Antenna Systems - Multiple Antennas with beam forming
- Single spatial stream/Standard throughput (e.g. IEEE 802.11™ legacy mode)
- High Throughput (> 1 spatial stream) using Nominal Channel Bandwidth 1
- High Throughput (> 1 spatial stream) using Nominal Channel Bandwidth 2

NOTE2: Add more lines if more channel bandwidths are supported.

h) In case of Smart Antenna Systems:

- The number of Receive chains:
- The number of Transmit chains:
- symmetrical power distribution
- asymmetrical power distribution

In case of beam forming, the maximum (additional) beam forming gain: dB

NOTE: The additional beam forming gain does not include the basic gain of a single antenna.

i) Operating Frequency Range(s) of the equipment:

- Operating Frequency Range 1: 2412 MHz to 2472 MHz
- Operating Frequency Range 2: 2422 MHz to 2462 MHz

NOTE: Add more lines if more Frequency Ranges are supported.

j) Occupied Channel Bandwidth(s):

- Nominal Channel Bandwidth 1: 13.257MHz
- Nominal Channel Bandwidth 2: 35.577MHz

NOTE: Add more lines if more channel bandwidths are supported.

k) Type of Equipment (stand-alone, combined, plug-in radio device, etc.):

- Stand-alone
- Combined Equipment
- Plug-in radio device



Other

l) The normal and the extreme operating conditions that apply to the equipment:

Normal operating conditions (if applicable):

Operating temperature: 25° C

Other (please specify if applicable):

Extreme operating conditions:

Operating temperature range: Minimum: -20 °C Maximum 55°C

Other (please specify if applicable): Minimum: Maximum

Details provided are for the: stand-alone equipment

combined (or host) equipment

test jig

m) The intended combination(s) of the radio equipment power settings and one or more antenna assemblies and their corresponding e.i.r.p. levels:

• Antenna Type

Integral Antenna (information to be provided in case of conducted measurements)

Antenna Gain: 2 dBi

If applicable, additional beamforming gain (excluding basic antenna gain): dB

Temporary RF connector provided

No temporary RF connector provided

Dedicated Antennas (equipment with antenna connector)

Single power level with corresponding antenna(s)

Multiple power settings and corresponding antenna(s)

Number of different Power Levels:

Power Level 1: dBm

Power Level 2: dBm

Power Level 3: dBm

NOTE 1: Add more lines in case the equipment has more power levels.

NOTE 2: These power levels are conducted power levels (at antenna connector).

• For each of the Power Levels, provide the intended antenna assemblies, their corresponding gains (G) and the resulting e.i.r.p. levels also taking into account the beamforming gain (Y) if applicable

Power Level 1: dBm

Number of antenna assemblies provided for this power level:



Assembly #	Gain (dBi)	e.i.r.p. (dBm)	Part number or model name
1			
2			
3			
4			

NOTE 3: Add more rows in case more antenna assemblies are supported for this power level.

Power Level 2: dBm

Number of antenna assemblies provided for this power level:

Assembly #	Gain (dBi)	e.i.r.p. (dBm)	Part number or model name
1			
2			
3			
4			

NOTE 4: Add more rows in case more antenna assemblies are supported for this power level.

Power Level 3: dBm

Number of antenna assemblies provided for this power level:

Assembly #	Gain (dBi)	e.i.r.p. (dBm)	Part number or model name
1			
2			
3			
4			

NOTE 5: Add more rows in case more antenna assemblies are supported for this power level.

n) The nominal voltages of the stand-alone radio equipment or the nominal voltages of the combined equipment or test jig in case of plug-in devices:

Details provided are for the: stand-alone equipment

combined equipment

test jig

Supply Voltage AC mains State AC voltage V

DC State DC voltage :12V

In case of DC, indicate the type of power source

Internal Power Supply

External Power Supply or AC/DC adapter



- Battery: V
- Other:

o) Describe the test modes available which can facilitate testing:

The EUT can be into the Engineer mode for testing.

p) The equipment type (e.g. Bluetooth®, IEEE 802.11™, IEEE 802.15.4™, proprietary, etc.):

IEEE 802.11™

q) If applicable, the statistical analysis referred to in clause 5.4.1 q)

(to be provided as separate attachment)

r) If applicable, the statistical analysis referred to in clause 5.4.1 r)

(to be provided as separate attachment)

s) Geo-location capability supported by the equipment:

- Yes
- The geographical location determined by the equipment as defined in clause 4.3.1.13.2 or clause 4.3.2.12.2 is not accessible to the user
- No

ANNEX E.3

From all combinations of conducted power settings and intended antenna assembly(ies) specified in clause 5.4.1 m),specify the combination resulting in the highest e.i.r.p. for the radio equipment.

Unless otherwise specified in ETSI EN 300 328, this power setting is to be used for testing against the requirements of ETSI EN 300 328. In case there is more than one such conducted power setting resulting in the same (highest) e.i.r.p. level, the highest power setting is to be used for testing. See also ETSI EN 300 328, clause 5.3.2.3.

Highest overall e.i.r.p. value: dBm	
Corresponding Antenna assembly gain: dBi	Antenna Assembly #:
Corresponding conducted power setting: dBm (also the power level to be used for testing)	Listed as Power Setting #:

ANNEX E.4.1

ITU Class(es) of emission:

Can the transmitter operate unmodulated? yes no

ANNEX E.4.2

The transmitter is intended for: Continuous duty
Intermittent duty
Continuous operation possible for testing purposes



ANNEX E.4.3

- The equipment submitted are representative production models
- If not, the equipment submitted are pre-production models?
 - If pre-production equipment are submitted, the final production equipment will be identical in all respects with the equipment tested
 - If not, supply full details

ANNEX E.4.4

- Spare batteries (e.g. for portable equipment)
- Battery charging device
- External Power Supply or AC/DC adapter
- Test jig or interface box
- RF test fixture (for equipment with integrated antennas)
- Combined equipment Manufacturer:
 - Model #:
 - Model name:
- User Manual
- Technical documentation (Handbook and circuit diagrams)

3.2 Tested System Details

None.

3.3 Test Mode Description

Mode	data rate (Mbps)	Channel	Frequency (MHz)
802.11b	11	Low :CH1	2412
	11	Middle: CH7	2442
	11	High: CH13	2472
802.11g	54	Low :CH1	2412
	54	Middle: CH7	2442
	54	High: CH13	2472
802.11n HT20	MCS1	Low :CH1	2412
	MCS1	Middle: CH7	2442
	MCS1	High: CH13	2472
802.11n HT40	MCS1	Low :CH3	2412
	MCS1	Middle: CH7	2442
	MCS1	High: CH11	2472



3.4 Test Conditions

	Normal Conditions	Extreme Conditions	
Temperature range	25°C	HTHV	DC 13.2V, 55°C
		HTLV	DC 13.2V, -20°C
Power supply	DC 12V	LTLV	DC 10.8V, -20°C
		LTHV	DC 10.8V, 55°C

Note 1: The test procedure described in clause 5.1 of EN300 328 was used for extreme test procedure.
2: The Extreme Temperature and Extreme Voltages declared by the manufacturer.

3.5 Test Uncertainty

Item	MU	Remark
Uncertainty for Conducted Emission Test	2.50dB	
Uncertainty for Radiation Emission test in 3m chamber (30MHz to 1GHz)	3.04dB	Polarize: V
	3.02dB	Polarize: H
Uncertainty for Radiation Emission test in 3m chamber (Above)	3.56dB	Polarize: H
	3.84dB	Polarize: V
Uncertainty for radio frequency	1×10^{-9}	
Uncertainty for conducted RF Power	0.65dB	
Uncertainty for temperature	0.6°C	
Uncertainty for humidity	1%	

**4. TEST INSTRUMENT USED**

For All Test					
Equipment	Manufacturer	Model#	Serial#	Last Cal.	Next Cal.
966 Chamber	ChengYu	966 Room	966	Nov. 25, 2019	Nov. 24, 2022
Spectrum Analyzer	Agilent	E4408B	MY50140780	Feb. 06, 2020	Feb. 05, 2021
Emi Receiver	R&S	ESRP7	101393	Feb. 06, 2020	Feb. 05, 2021
Amplifier	Schwarzbeck	BBV9743B	00153	Feb. 06, 2020	Feb. 05, 2021
Amplifier	EMEC	EM01G8GA	00270	Feb. 06, 2020	Feb. 05, 2021
Broadband Trilog Antenna	Schwarzbeck	VULB9162	00306	Feb. 07, 2020	Feb. 06, 2021
Horn Antenna	Schwarzbeck	BBHA9120D	02139	Feb. 07, 2020	Feb. 06, 2021
966 Cable 1#	ChengYu	966	004	Feb. 06, 2020	Feb. 05, 2021
966 Cable 2#	ChengYu	966	003	Feb. 06, 2020	Feb. 05, 2021
Active Loop Antenna	Daze	ZN30900A	SEL0097	Feb. 06, 2020	Feb. 05, 2021
Cable	Resenberger	N/A	No.1	Feb. 06, 2020	Feb. 05, 2021
Cable	SCHWARZBECK	N/A	No.2	Feb. 06, 2020	Feb. 05, 2021
Cable	SCHWARZBECK	N/A	No.3	Feb. 06, 2020	Feb. 05, 2021
Base Station	Agilent	E5515C	GB44300243	Feb. 06, 2020	Feb. 05, 2021
Temperature Controller	Terchy	MHQ	120	Feb. 06, 2020	Feb. 05, 2021
Splitter	Mini	PS3-7	4463	Feb. 06, 2020	Feb. 05, 2021
Attenuator	Agilent	8491B	MY39262165	Feb. 06, 2020	Feb. 05, 2021
Splitter	Mini-Circuits	ZAP-50W	NN256400424	Feb. 06, 2020	Feb. 05, 2021
Wideband Radio Communication Tester	R&s	CMW500	106504	Feb. 06, 2020	Feb. 05, 2021
Spectrum Analyzer	KEYSIGHT	N9020A	MY55370280	Feb. 06, 2020	Feb. 05, 2021
Signal Generator	Agilent	N5182A	MY46240766	Feb. 06, 2020	Feb. 05, 2021
Synthesized Sweeper	Agilent	83752B	3610A01631	Feb. 06, 2020	Feb. 05, 2021
USB Wideband Power Sensor	KEYSIGHT	U2021XA	MY55210018	Feb. 06, 2020	Feb. 05, 2021
USB Wideband Power Sensor	KEYSIGHT	U2021XA	MY54250005	Feb. 06, 2020	Feb. 05, 2021



5. RF OUTPUT POWER

5.1 Block Diagram Of Test Setup

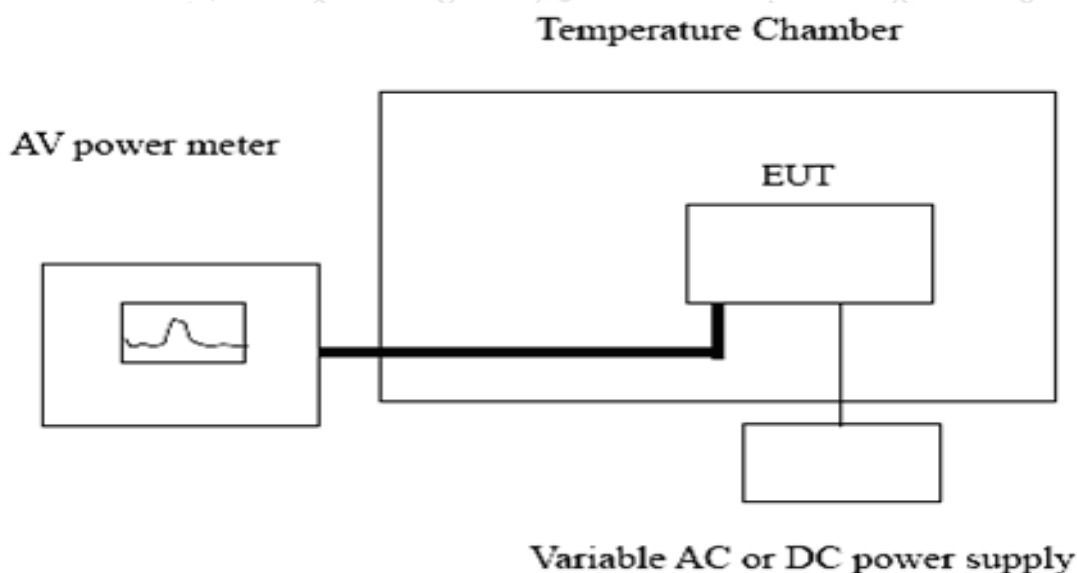

5.2 Limit

The RF output power for non-FHSS equipment shall be equal to or less than 20 dBm.

Notes: For Non-adaptive FHSS equipment, the manufacturer may have declared a reduced RF Output Power (see clause 5.4.1 m)) and associated Duty Cycle (see clause 5.4.1 e)) that will ensure that the equipment meets the requirement for the Medium Utilization (MU) factor further described in clause 4.3.2.5. This is verified by the conformance test referred to in clause 4.3.2.5.4.

For non-adaptive non-FHSS equipment, where the manufacturer has declared an RF output power of less than 20 dBm e.i.r.p., the RF output power shall be equal to or less than that declared value.

5.3 Test Procedure

Refer to ETSI EN 300 328 V2.2.2 Clause 5.4.2.2.1.1



5.4 Test Result

Total e.i.r.p (dBm) Result								
Mode	Test CH	Condition					Limit (dBm)	Result
		Normal	HTLV	LTLV	LTHV	HTHV		
802.11b	Low	7.80	7.72	8.02	7.91	7.89	20.00	Pass
	Middle	8.19	8.10	8.40	8.30	8.28	20.00	Pass
	High	8.35	8.26	8.58	8.46	8.44	20.00	Pass
802.11g	Low	6.16	6.09	6.32	6.23	6.22	20.00	Pass
	Middle	6.21	6.15	6.38	6.29	6.28	20.00	Pass
	High	6.59	6.52	6.77	6.67	6.66	20.00	Pass
802.11n HT20	Low	5.45	5.48	5.60	5.52	5.51	20.00	Pass
	Middle	5.67	5.71	5.83	5.75	5.74	20.00	Pass
	High	5.65	5.69	5.81	5.73	5.72	20.00	Pass
802.11n HT40	Low	6.38	6.43	6.56	6.46	6.45	20.00	Pass
	Middle	6.71	6.75	6.89	6.79	6.78	20.00	Pass
	High	6.46	6.50	6.64	6.54	6.53	20.00	Pass



6. POWER SPECTRAL DENSITY

6.1 Block Diagram of Test Setup

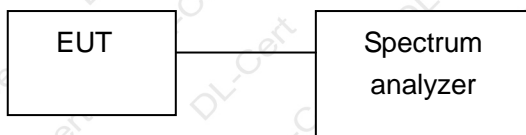

6.2 Test Standard and Limit

The maximum Power Spectral Density for non-FHSS equipment is 10 dBm per MHz.

6.3 Test Procedure

Refer to ETSI EN 300 328 V2.2.2 Clause 5.4.3

Connect the UUT to the spectrum analyzer and use the following settings:

Start Frequency	2400 MHz
Stop Frequency	2483.5 MHz
RBW	10KHz
VBW	30KHz
Detector	RMS
Sweep points	>8350
Trace	Max Hold
Trigger	Free Run

6.4 Test Result

Mode	Channel	Power Spectral Density (dBm/MHz)	Limit (dBm/MHz)	Conclusion
802.11b	Low	-6.45	10.00	PASS
	Middle	-6.33	10.00	PASS
	High	-6.25	10.00	PASS
802.11g	Low	-4.64	10.00	PASS
	Middle	-4.60	10.00	PASS
	High	-4.27	10.00	PASS
802.11n HT20	Low	-5.86	10.00	PASS
	Middle	-5.66	10.00	PASS
	High	-5.69	10.00	PASS
802.11n HT40	Low	-7.86	10.00	PASS
	Middle	-7.64	10.00	PASS
	High	-7.94	10.00	PASS

7. ADAPTIVITY

7.1 Block Diagram of Test Setup

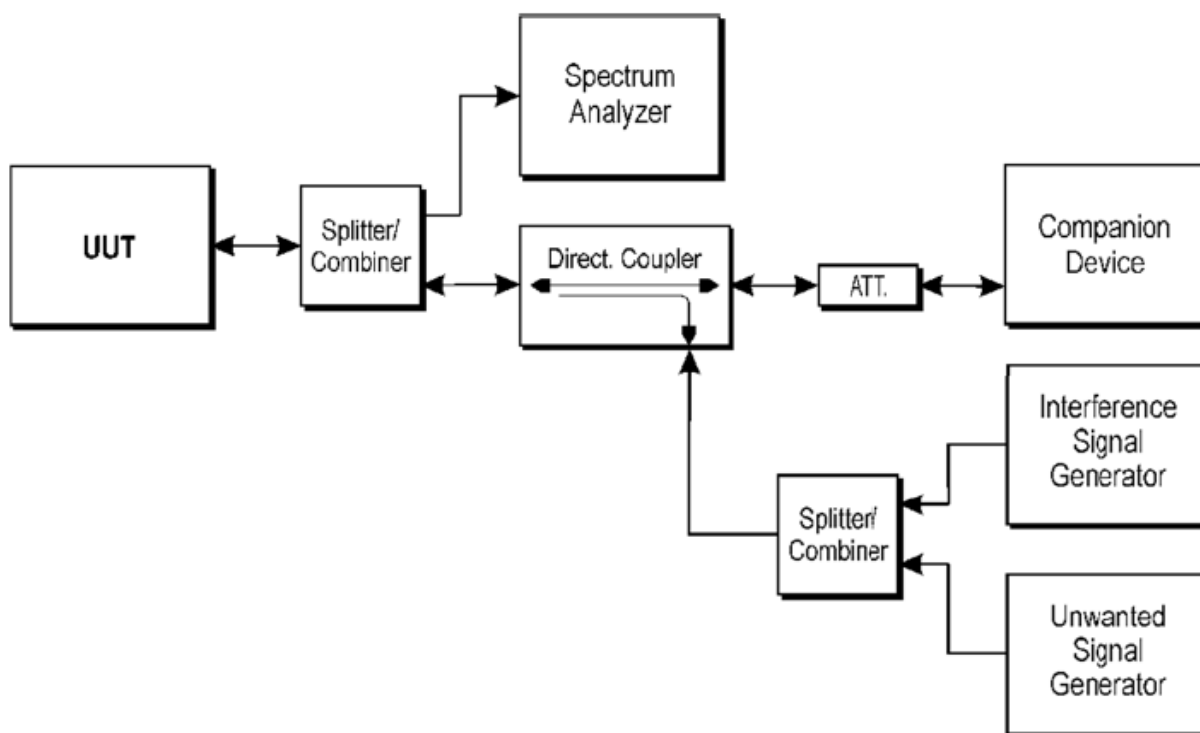

Figure 5: Test set-up for verifying the adaptivity of an equipment

7.2 Test Standard and Limit

Adaptive non-FHSS equipment using DAA shall comply with the following minimum set of requirements:

- 1) During normal operation, the equipment shall evaluate the presence of a signal on its current operating channel(s). If it is determined that a signal is present with a level above the detection threshold defined in step 5 that channel shall be marked as 'unavailable'.
- 2) The channel(s) shall remain unavailable for a minimum time equal to 1 s after which the channel may be considered again as an 'available' channel
- 3) The total time during which an equipment has transmissions on a given channel without re-evaluating the availability of that channel, is defined as the Channel Occupancy Time. The Channel Occupancy Time shall be less than 40 ms. Each such transmission sequence shall be followed by an Idle Period (no transmissions) of minimum 5 % of the Channel Occupancy Time with a minimum of 100 μ s. After this, the procedure as in step 1 needs to be repeated.
- 4) The detection threshold shall be proportional to the transmit power of the transmitter: for a 20 dBm e.i.r.p. transmitter the detection threshold level (TL) shall be equal to or less than -70 dBm/MHz at the input to the receiver assuming a 0 dBi (receive) antenna assembly. This threshold level (TL) may be corrected for the (receive) antenna assembly gain (G); however, beamforming gain (Y) shall not be taken into account. For power levels less than 20 dBm e.i.r.p., the detection threshold level may be relaxed to:

$$TL = -70 \text{ dBm/MHz} + 10 \times \log_{10} (100 \text{ mW} / P_{\text{out}}) \text{ (} P_{\text{out}} \text{ in mW e.i.r.p.)}$$

- 5) The equipment shall comply with the requirements defined in step 1 to step 4 of the present clause in the



presence of an unwanted CW signal as defined in table 9.

Table 9: Unwanted Signal parameters

Wanted signal mean power from companion device (dBm)	Unwanted signal frequency (MHz)	Unwanted CW signal power (dBm)
-30 (see note 2)	2 395 or 2 488,5 (see note 1)	-35 (see note 2)
<p>NOTE 1: The highest frequency shall be used for testing operating channels within the range 2 400 MHz to 2 442 MHz, while the lowest frequency shall be used for testing operating channels within the range 2 442 MHz to 2 483,5 MHz. See clause 5.4.6.1.</p> <p>NOTE 2: The level specified is the level at the UUT receiver input assuming a 0 dBi antenna assembly gain. In case of conducted measurements, this level has to be corrected for the (in-band) antenna assembly gain (G). In case of radiated measurements, this level is equivalent to a power flux density in front of the UUT antenna.</p>		

7.3 Test Procedure

Refer to ETSI EN 300 328 V2.2.2 Clause 5.4.6

7.4 Test Result

Test mode	Stop time after interfering signal(ms)	
Channel	Low	High
802.11b mode	173.19	178.73
802.11g mode	208.67	167.32
802.11n HT20 mode	208.72	167.31
802.11n HT40 mode	186.87	217.21
<p>Remark: 1: Short Control Signalling Transmissions of adaptive equipment using wide band modulations other than FHSS shall have a maximum duty cycle of 10 % within an observation period of 50 ms.</p>		



Short Control Signalling Transmissions						
Test mode	Channel	Channel occupancy time (ms)	Idle time (ms)	Pulse width (ms)	Maximum duty cycle(%)	Conclusion
802.11b mode	Low	1.53	0.05	1.43	2.85	Pass
	High	1.44	0.10	1.43	2.85	Pass
802.11g mode	Low	1.24	0.050	1.225	2.450	Pass
	High	1.29	0.050	1.225	2.450	Pass
802.11n HT20 mode	Low	1.26	0.050	1.225	2.450	Pass
	High	1.31	0.050	1.225	2.450	Pass
802.11n HT40 mode	Low	1.74	0.050	1.649	3.298	Pass
	High	1.68	0.050	1.649	3.298	Pass

Note:

- 1.Channel occupancy time must between on 1.65ms to 13.25ms
2. Idle time must longer than 20us.
3. Duty cycle=Pulse time/50ms.
4. Short Control Signalling Transmissions of adaptive equipment using wide band modulations other than FHSS shall have a maximum duty cycle of 10 % within an observation period of 50ms.



802.11b Low channel

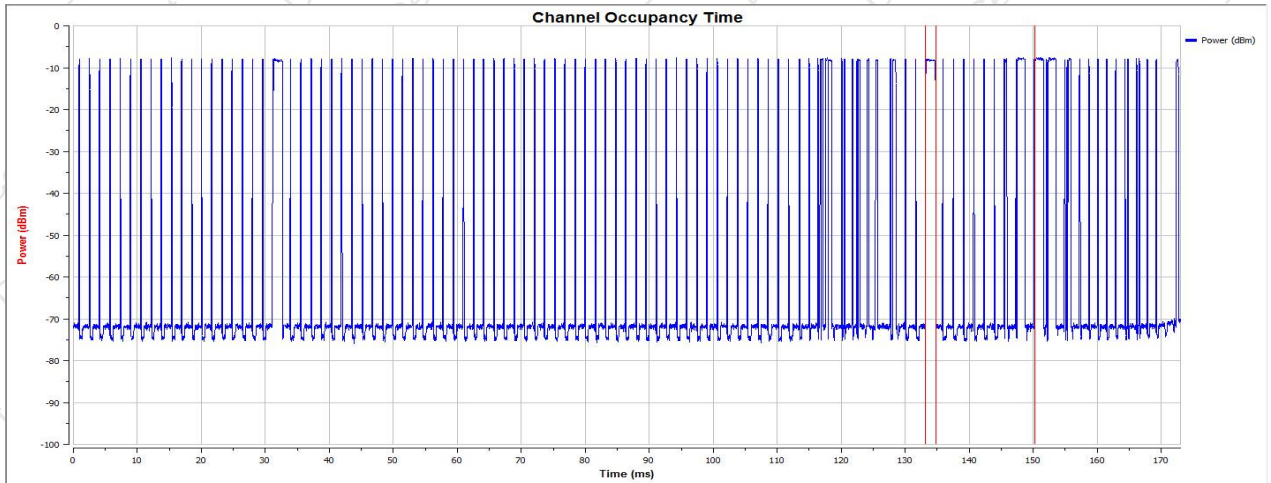
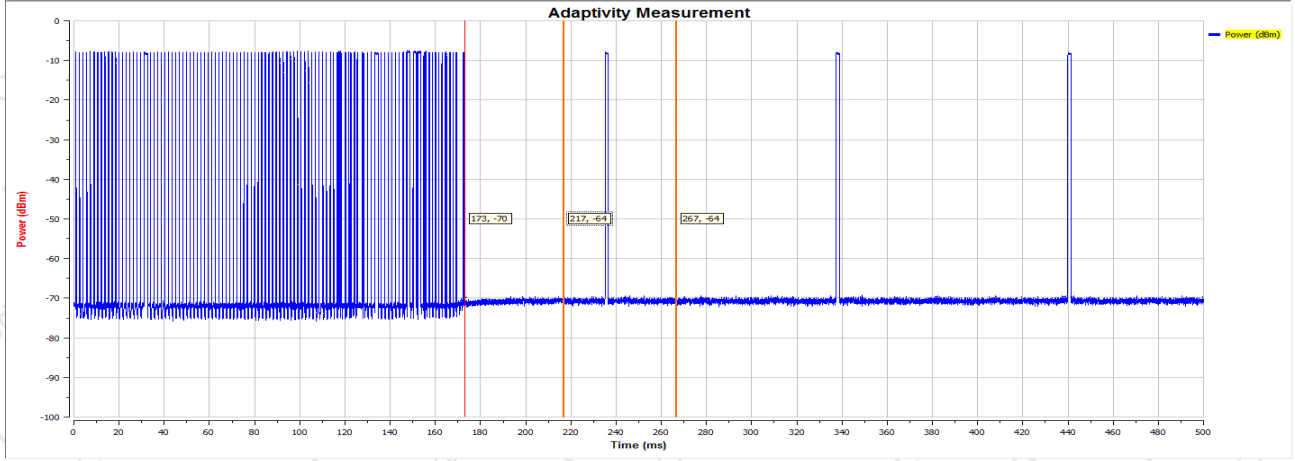

Channel Occupancy Time Info

Maximum Channel Occupancy Time (ms) : 1.55
Minimum Channel Occupancy Time (ms) : 0.00
*COT Time must be between on 1.625ms to 13ms
Idle Time (us) : 50.00
*Idle Time must longer than 20us

Suggested q Number : 4

Idle Time / Max COT (%) : 3.23

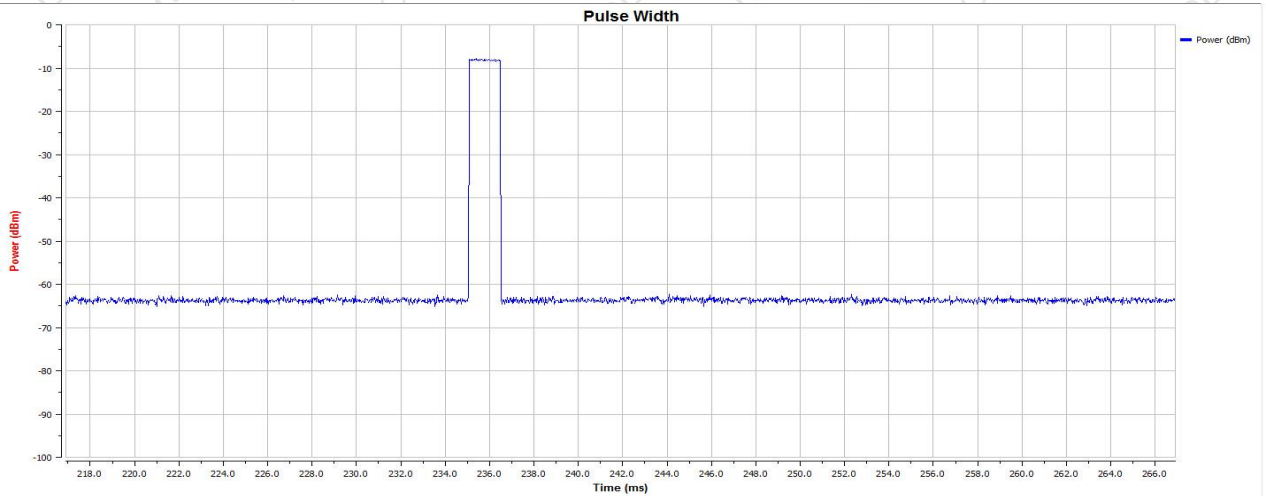

Pulse Width Info

T1 (ms) : 216.91
T2 (ms) : 266.91

Pulse Width (ms) : 1.42500305175781

Duty Cycle (%) : 2.85000610351563



802.11b High channel

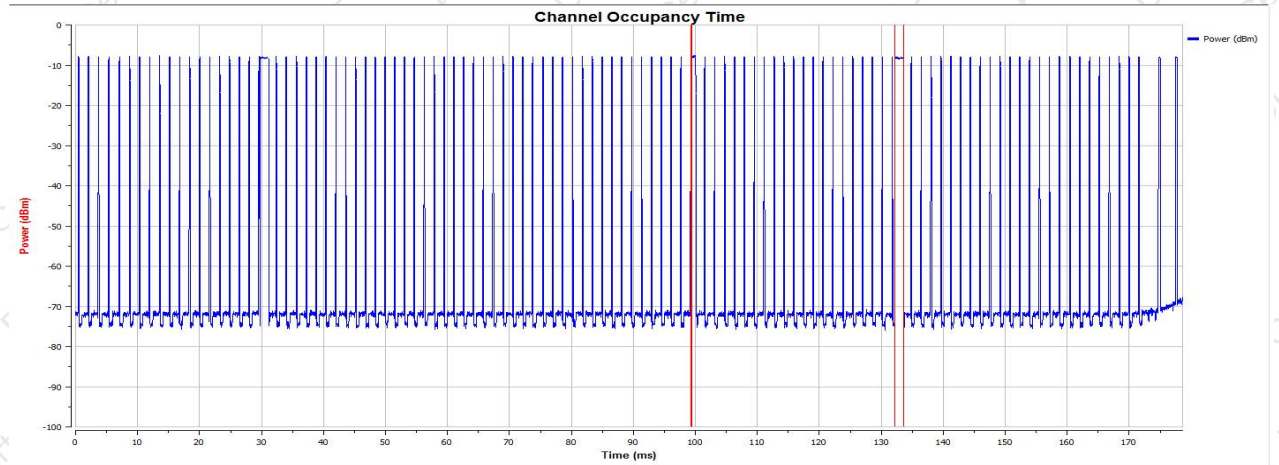
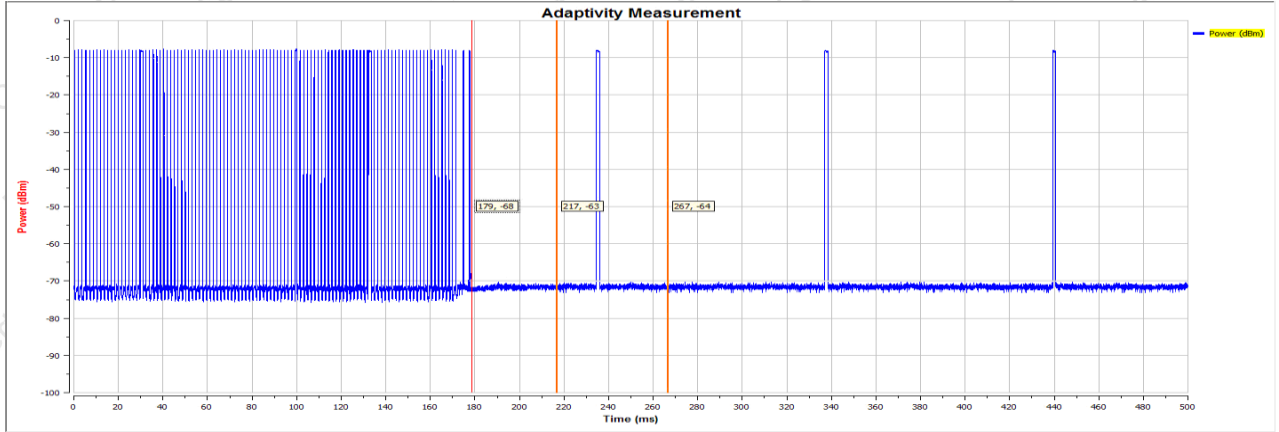

Channel Occupancy Time Info
Maximum Channel Occupancy Time (ms) : 1.40
Minimum Channel Occupancy Time (ms) : 0.00
•COT Time must between on 1.625ms to 13ms
Idle Time (us) : 100.00
•Idle Time must longer than 20us

Suggested q Number : 3

Idle Time / Max COT (%) : 7.14

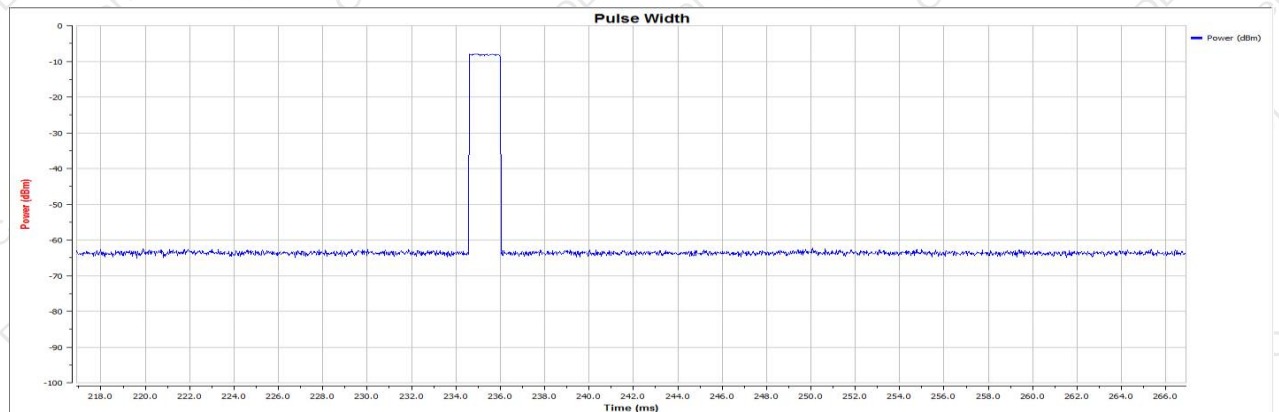

Pulse Width Info
T1 (ms) : 236.91
T2 (ms) : 266.91

Pulse Width (ms) : 1.39999389648438
Duty Cycle (%) : 2.79998779296875



802.11g Low channel

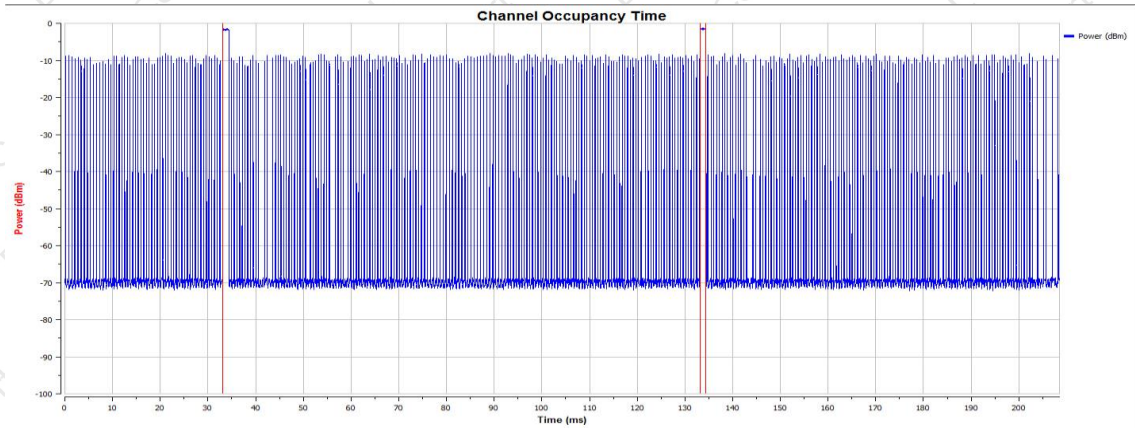
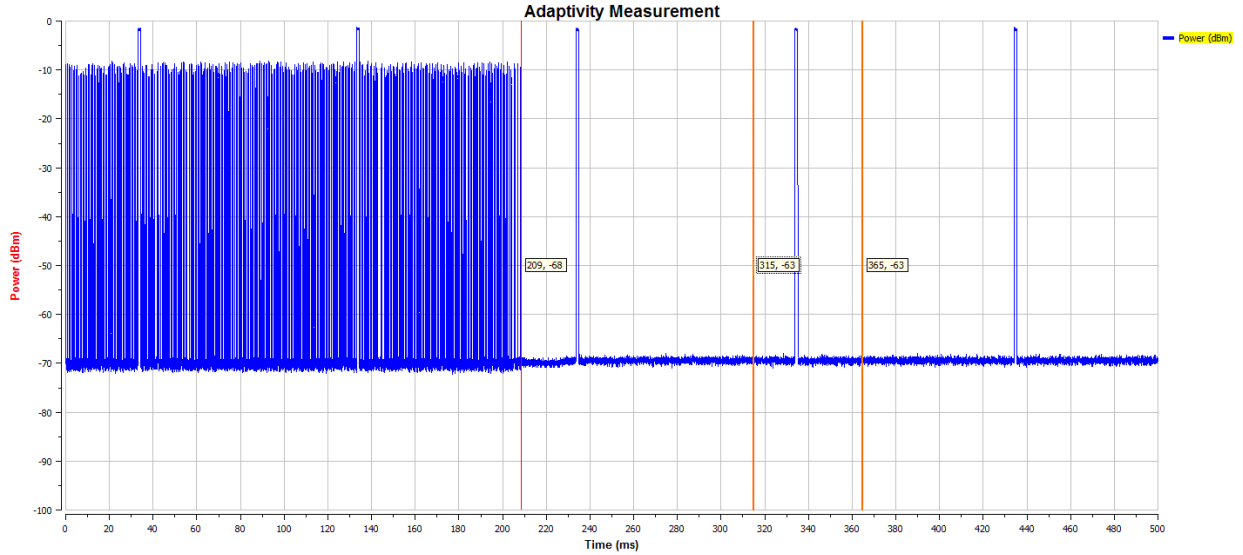

Channel Occupancy Time Info
Maximum Channel Occupancy Time (ms) : 1.23
Minimum Channel Occupancy Time (ms) : 0.00
*COT Time must between on 1.625ms to 13ms
Idle Time (us) : 50.00
*Idle Time must longer than 20us

Suggested q Number : 3

Idle Time / Max COT (%) : 4.08

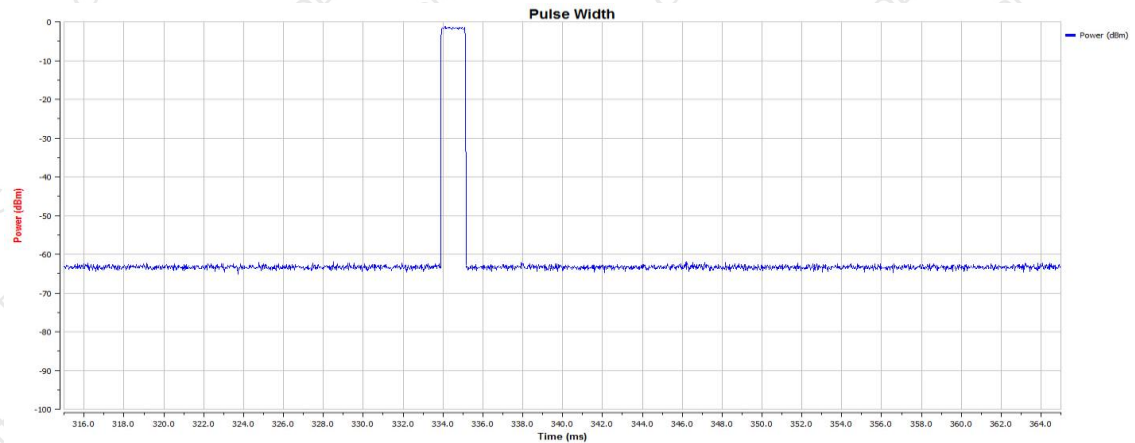

Pulse Width Info

Parameter	Value
T1 (ms)	334.99
T2 (ms)	364.99
Pulse Width (ms)	1.22500610351563
Duty Cycle (%)	2.45001220703125



802.11g High channel

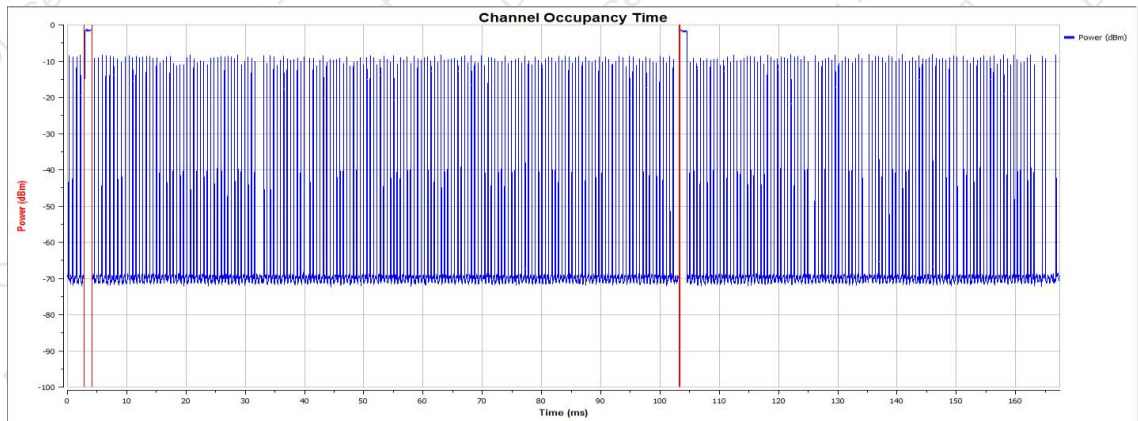
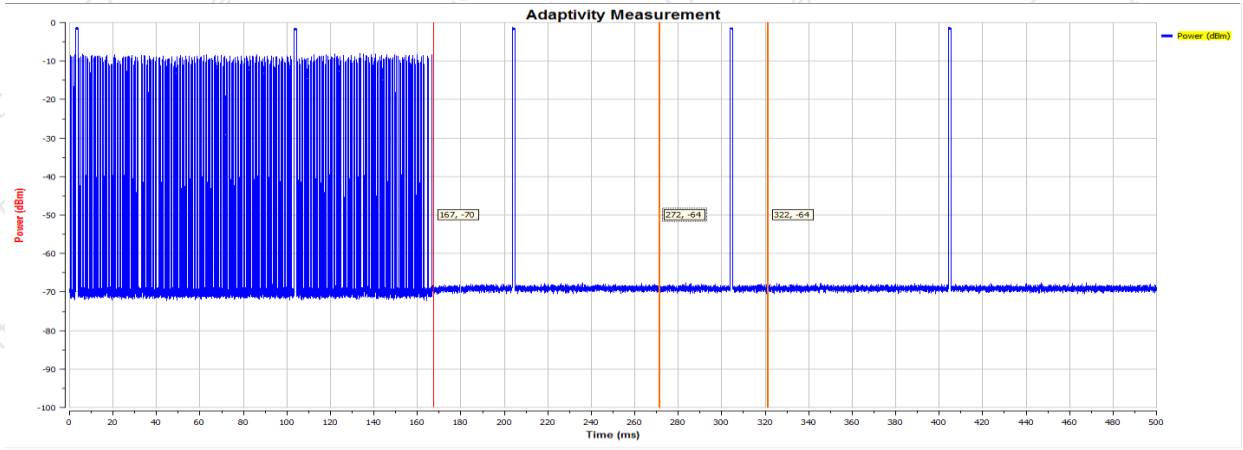

Channel Occupancy Time Info
Maximum Channel Occupancy Time (ms) : 1.27
Minimum Channel Occupancy Time (ms) : 0.00
*COT Time must between on 1.625ms to 13ms
Idle Time (us) : 50.00
*Idle Time must longer than 20us

Suggested q Number : 3

Idle Time / Max COT (%) : 3.92

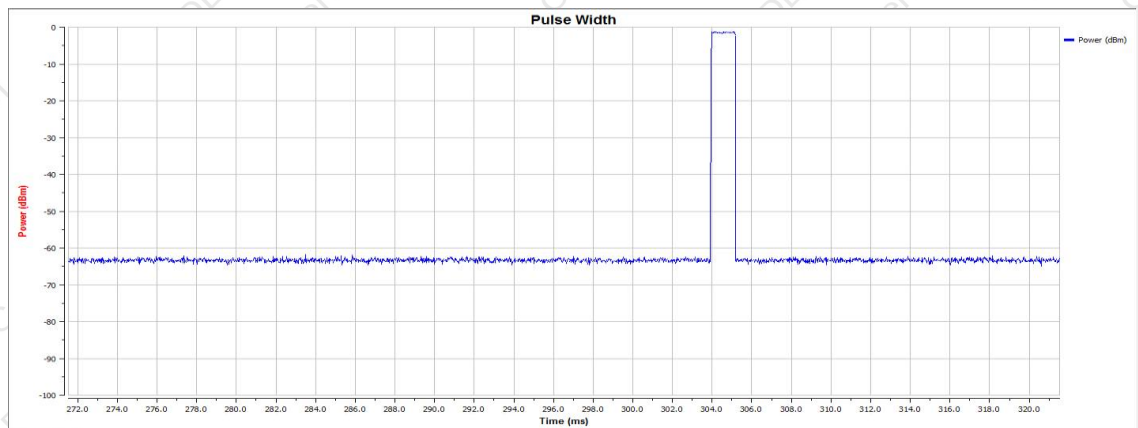

Pulse Width Info
T1 (ms) : 271.53
T2 (ms) : 323.53

Pulse Width (ms) : 1.22500610351563

Duty Cycle (%) : 2.45001220703125



802.11n HT20 Low channel

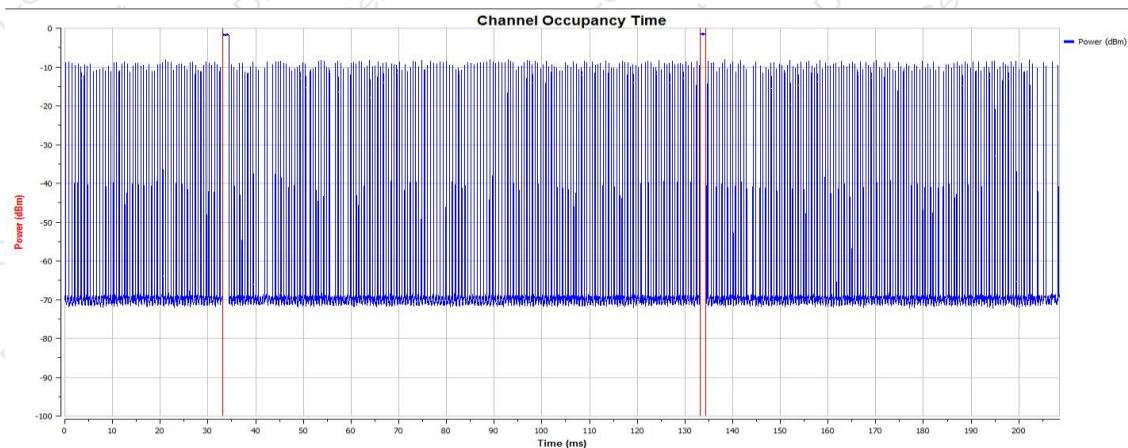
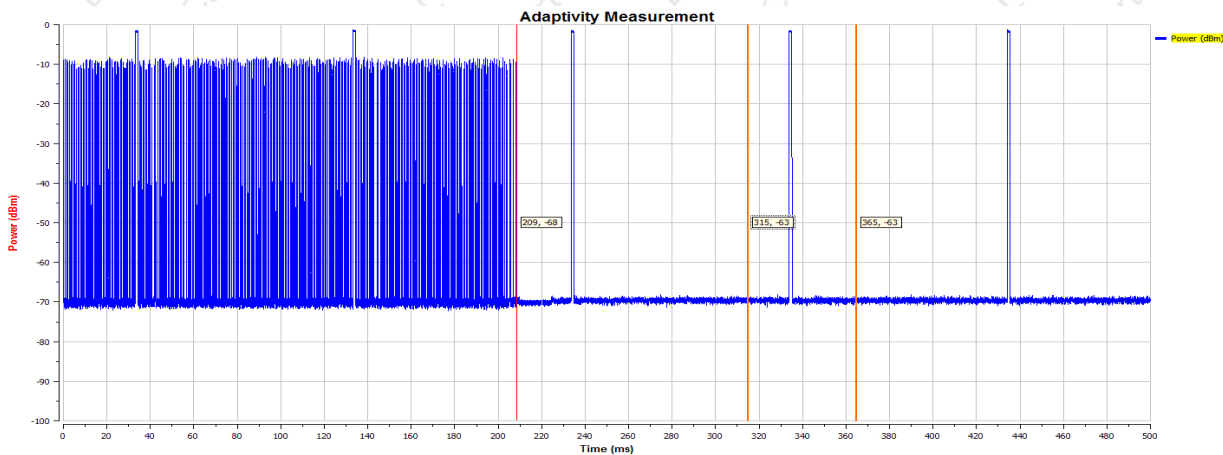

Channel Occupancy Time Info
Maximum Channel Occupancy Time (ms) : 1.23
Minimum Channel Occupancy Time (ms) : 0.00
*COT Time must between on 1.625ms to 13ms
Idle Time (us) : 50.00
*Idle Time must longer than 20us

Suggested q Number : 3
Idle Time / Max COT (%) : 4.08

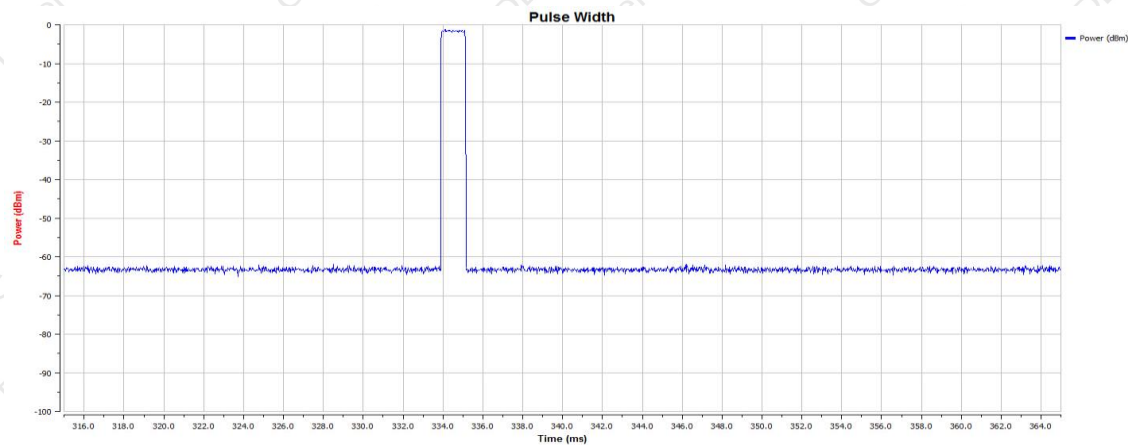

Pulse Width Info
T1 (ms) : 334.99
T2 (ms) : 364.99
Pulse Width (ms) : 1.22500610351563
Duty Cycle (%) : 2.45001220703125



802.11n HT20 High channel

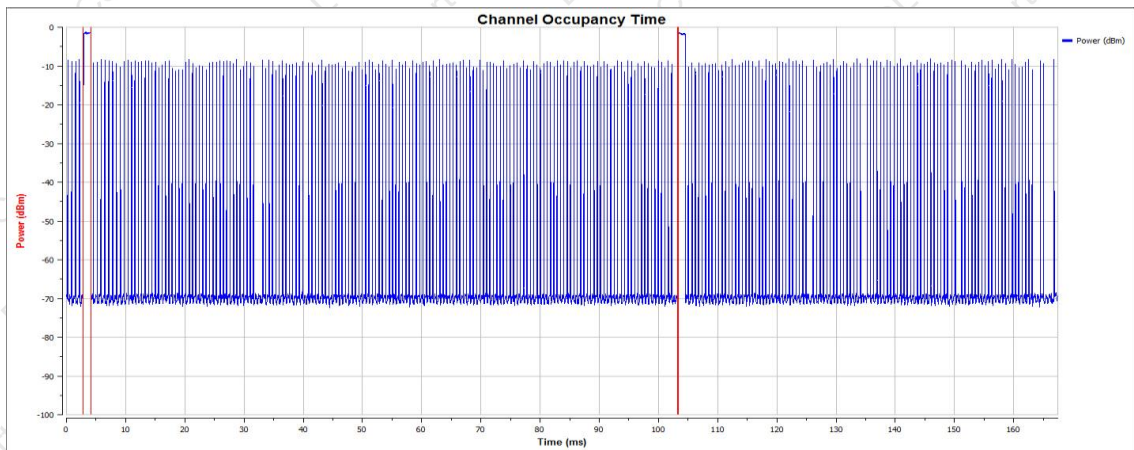
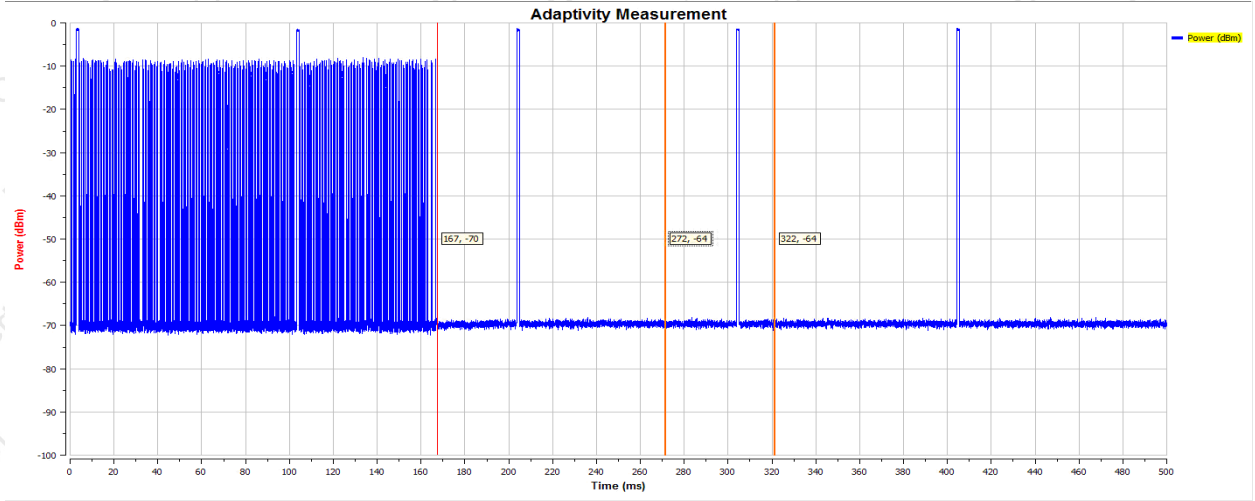

Channel Occupancy Time Info

Maximum Channel Occupancy Time (ms) : 1.27
Minimum Channel Occupancy Time (ms) : 0.00
*COT Time must between on 1.625ms to 13ms

Idle Time (us) : 50.00
*Idle Time must longer than 20us

Suggested q Number : 3

Idle Time / Max COT (%) : 3.92

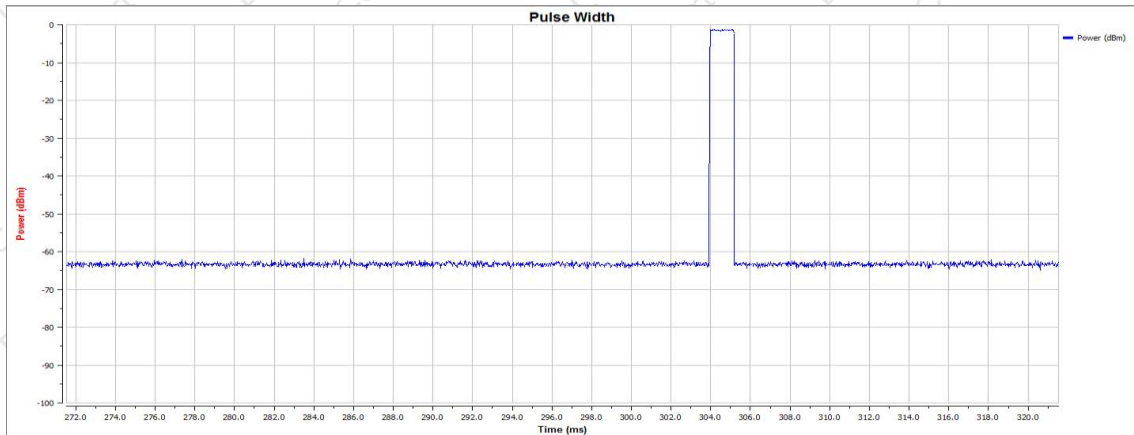

Pulse Width Info

T1 (ms) : 271.53
T2 (ms) : 321.53

Pulse Width (ms) : 1.22500610351563
Duty Cycle (%) : 2.45001220703125



802.11n HT40 Low channel

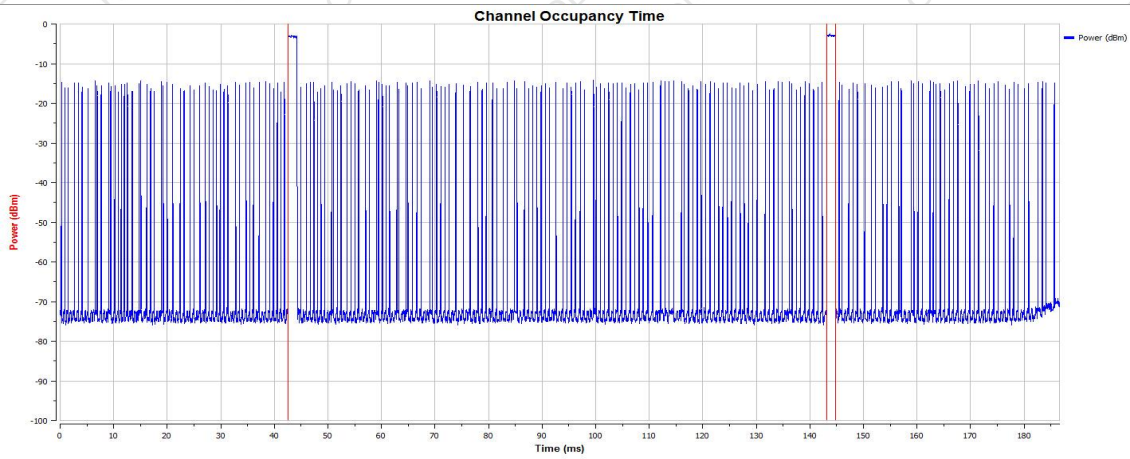
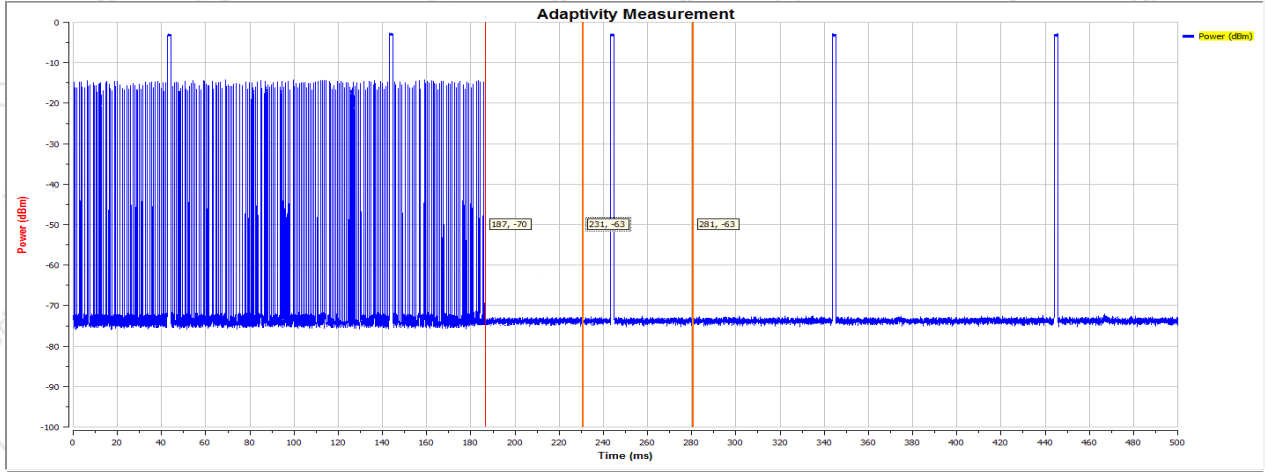

Channel Occupancy Time Info
Maximum Channel Occupancy Time (ms) : 1.70
Minimum Channel Occupancy Time (ms) : 0.00
*COT Time must between on 1.625ms to 13ms
Idle Time (us) : 50.00
*Idle Time must longer than 20us

Suggested q Number : 4

Idle Time / Max COT (%) : 2.94

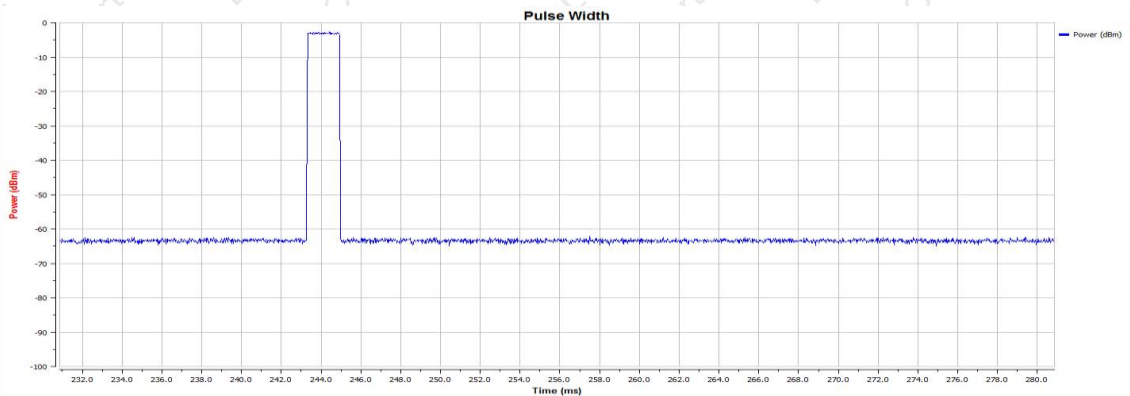

Pulse Width Info
T1 (ms) : 230.86
T2 (ms) : 280.86

Pulse Width (ms) : 1.64999389648438
Duty Cycle (%) : 3.29998779296875



802.11n HT40 High channel

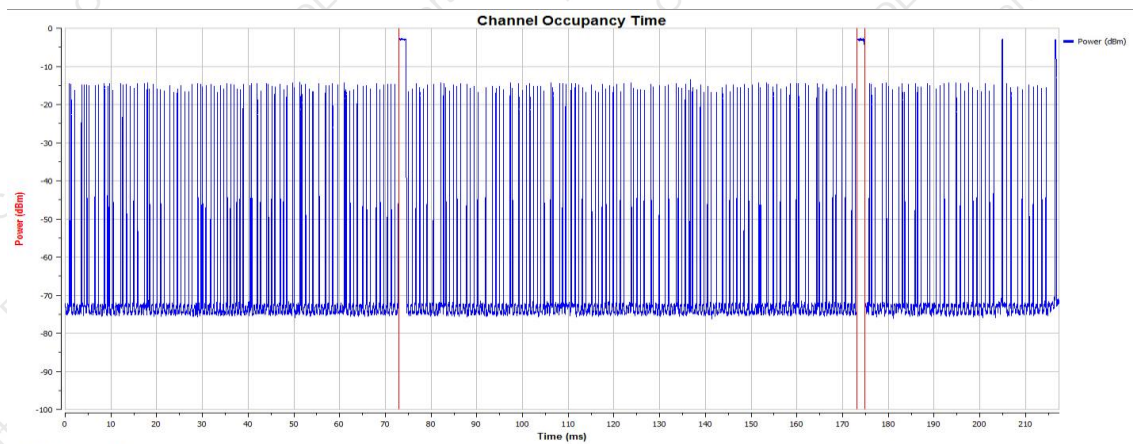
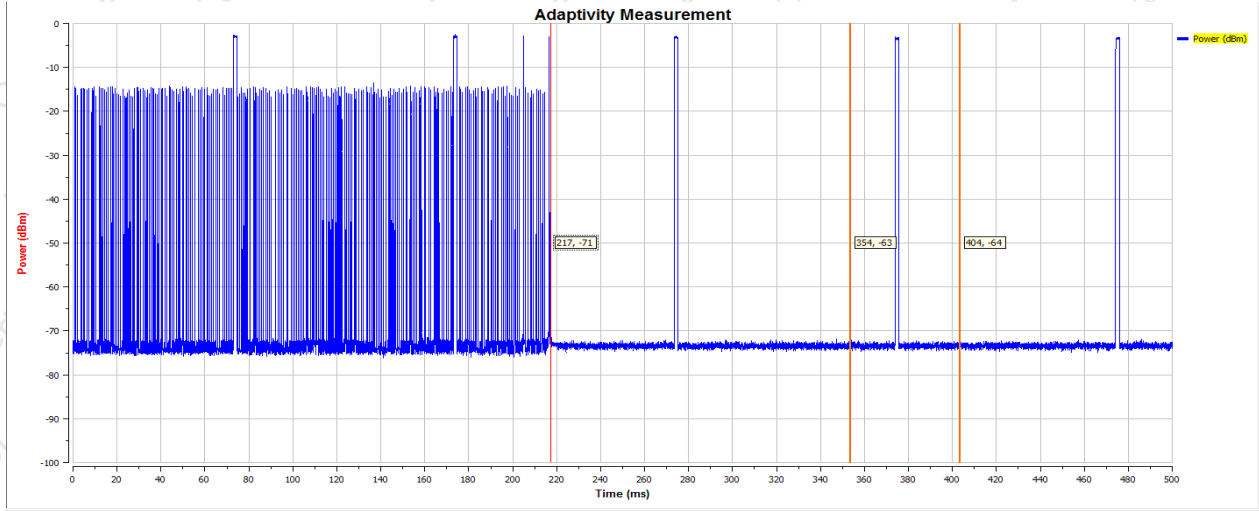

Channel Occupancy Time Info
 Maximum Channel Occupancy Time (ms) : 1.65
 Minimum Channel Occupancy Time (ms) : 0.00
 *COT Time must between on 1.625ms to 13ms
 Idle Time (us) : 50.00
 *Idle Time must longer than 20us

Suggested q Number : 4

Idle Time / Max COT (%) : 3.03

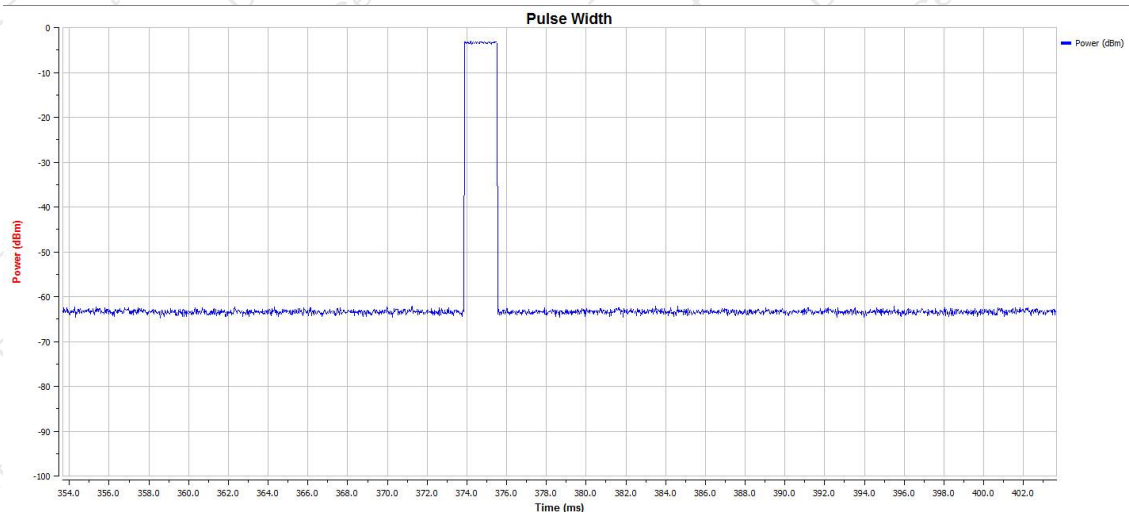

Pulse Width Info

T1 (ms) : 353.67 **Pulse Width (ms) : 1.64999389648438**

T2 (ms) : 403.67 **Duty Cycle (%) : 3.29998779296875**



8. OCCUPIED CHANNEL BANDWIDTH

8.1 Block Diagram of Test Setup

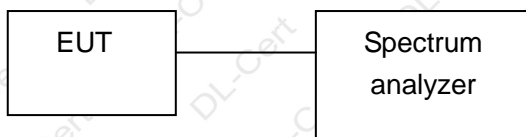

8.2 Test Standard and Limit

The Occupied Channel Bandwidth shall be within the band given in 2.4GHz to 2.4835GHz..

In addition, for non-adaptive non-FHSS equipment with e.i.r.p. greater than 10 dBm, the Occupied Channel Bandwidth shall be equal to or less than 20MHz.

8.3 Test Procedure

Refer to ETSI EN 300 328 V2.2.2 Clause 5.4.7

Connect the UUT to the spectrum analyzer and use the following settings:

Centre Frequency:	The centre frequency of the channel under test
RBW	~ 1 % of the span without going below 1 %
VBW	3 × RBW
Frequency Span:	2 × Nominal Channel Bandwidth
Detector Mode:	RMS
Trace Mode:	Max Hold
Sweep time:	1s

8.4 Test Result

Test Mode	Test Channel	Occupied Bandwidth	Measured Frequency		Limit	Result
			F _L (MHz)	F _H (MHz)		
802.11b	Low	13.257	2405.263	/	>2400MHz And <2483.5MHz	Pass
	High	13.260	/	2478.754		Pass
802.11g	Low	16.208	2403.722	/		Pass
	High	16.202	/	2480.224		Pass
802.11n HT20	Low	17.368	2403.143	/		Pass
	High	17.366	/	2480.831		Pass
802.11n HT40	Low	35.577	2403.894	/		Pass
	High	35.575	/	2480.116		Pass

9. TRANSMITTER UNWANTED EMISSIONS IN THE OUT-OF-BAND DOMAIN

9.1 Block Diagram of Test Setup

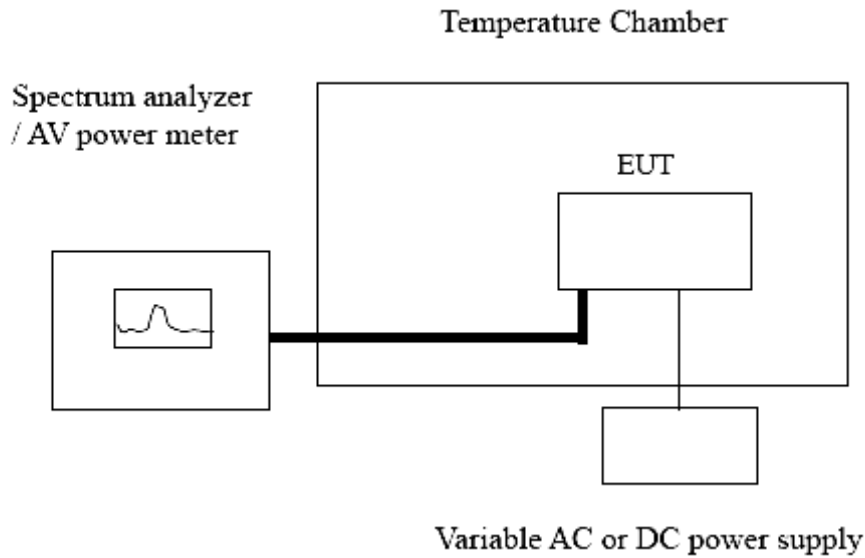

9.2 Test Standard and Limit

The transmitter unwanted emissions in the out-of-band domain shall not exceed the values provided by the mask in figure 3.

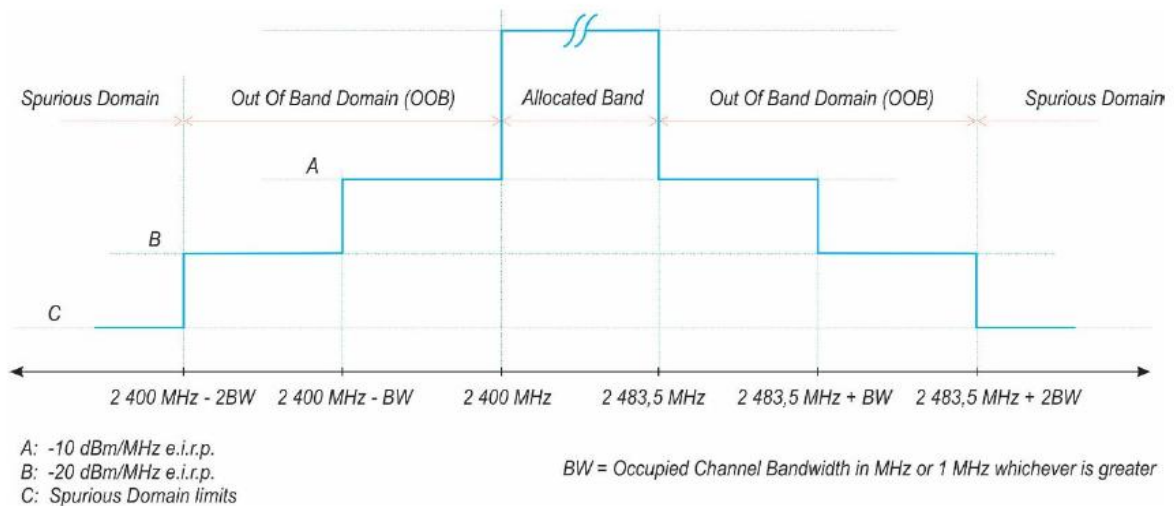

Figure 3: Transmit mask

9.3 Test Procedure

Refer to ETSI EN 300 328 V2.2.0 Clause 5.4.8.

Connect the UUT to the spectrum analyzer and use the following settings:

RBW/BW	1MHz/3MHz
Span	0Hz
Filter mode	Channel filter



Sweep mode	Continuous
Sweep Points	5000
Detector	RMS
Trace mode	Clear/Write
Trigger Mode	Video trigger

9.4 Test Result

Test Mode	Test Condition	Lower Band Edge		Higher Band Edge	
		Segment A (dBm/MHz)	Segment B (dBm/MHz)	Segment A (dBm/MHz)	Segment B (dBm/MHz)
802.11b	Normal	-50.81	-63.17	-41.17	-56.38
	HTLV	-50.56	-62.86	-40.96	-56.10
	LTLV	-50.76	-63.11	-41.13	-56.32
	LTHV	-50.71	-63.04	-41.09	-56.27
	HTHV	-50.61	-62.91	-41.01	-56.15
802.11g	Normal	-35.95	-57.21	-32.09	-57.29
	HTLV	-35.77	-57.92	-31.93	-57.00
	LTLV	-35.91	-58.15	-32.06	-57.23
	LTHV	-35.88	-58.09	-32.03	-57.18
	HTHV	-35.80	-57.98	-31.96	-57.06
802.11n HT20	Normal	-35.06	-58.74	-31.98	-57.65
	HTLV	-34.88	-58.45	-31.82	-57.36
	LTLV	-35.02	-59.20	-32.23	-58.09
	LTHV	-34.99	-59.14	-32.20	-58.03
	HTHV	-34.92	-59.02	-32.13	-57.92
802.11n HT40	Normal	-35.40	-65.39	-34.35	-56.16
	HTLV	-35.21	-65.06	-34.18	-55.87
	LTLV	-35.36	-65.32	-34.32	-56.10
	LTHV	-35.33	-65.26	-34.29	-56.05
	HTHV	-35.26	-65.13	-34.21	-55.93
Limit		-10	-20	-10	-20
Conclusion		PASS			
Remark: All modulations of EUT have been tested, but only show the test data of the worst case in this report.					



802.11 b CH Low (Normal Temp, Normal Voltage)

Channel	Antenna	Frequency	Level	Limit
CH Low-2412	Antenna 1	2399.5	-51.76	-10
CH Low-2412	Antenna 1	2398.5	-52.61	-10
CH Low-2412	Antenna 1	2397.5	-53.19	-10
CH Low-2412	Antenna 1	2396.5	-54.92	-10
CH Low-2412	Antenna 1	2395.5	-57.03	-10
CH Low-2412	Antenna 1	2394.5	-59.26	-10
CH Low-2412	Antenna 1	2393.5	-60.76	-10
CH Low-2412	Antenna 1	2392.5	-61.93	-10
CH Low-2412	Antenna 1	2391.5	-62.61	-10
CH Low-2412	Antenna 1	2390.5	-62.94	-10
CH Low-2412	Antenna 1	2389.5	-63.2	-10
CH Low-2412	Antenna 1	2388.5	-63.18	-10
CH Low-2412	Antenna 1	2387.5	-63.28	-10
CH Low-2412	Antenna 1	2386.996	-63.32	-20
CH Low-2412	Antenna 1	2385.996	-63.46	-20
CH Low-2412	Antenna 1	2384.996	-63.59	-20
CH Low-2412	Antenna 1	2383.996	-63.73	-20
CH Low-2412	Antenna 1	2382.996	-63.9	-20
CH Low-2412	Antenna 1	2381.996	-63.97	-20
CH Low-2412	Antenna 1	2380.996	-64.06	-20
CH Low-2412	Antenna 1	2379.996	-64.12	-20
CH Low-2412	Antenna 1	2378.996	-64.16	-20
CH Low-2412	Antenna 1	2377.996	-64.23	-20
CH Low-2412	Antenna 1	2376.996	-64.25	-20
CH Low-2412	Antenna 1	2375.996	-64.36	-20
CH Low-2412	Antenna 1	2374.996	-64.34	-20

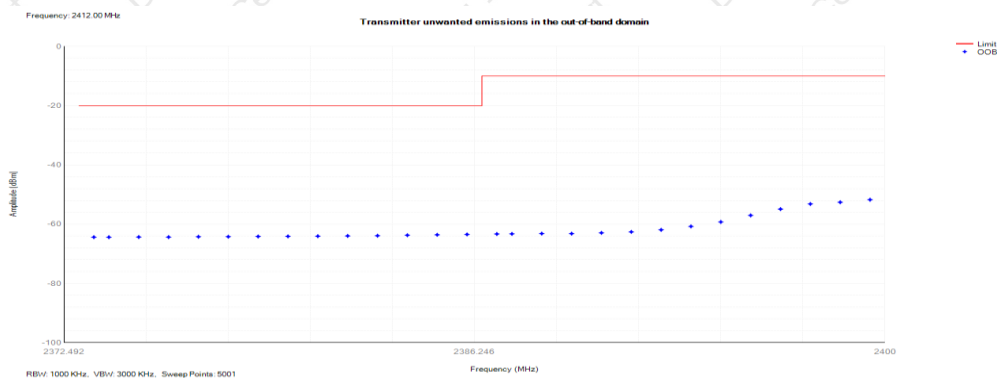



802.11 b CH High (Normal Temp, Normal Voltage)

Channel	Antenna	Frequency	Level	Limit
CH High-2472	Antenna 1	2484	-41.24	-10
CH High-2472	Antenna 1	2485	-42.26	-10
CH High-2472	Antenna 1	2486	-43.03	-10
CH High-2472	Antenna 1	2487	-44.68	-10
CH High-2472	Antenna 1	2488	-47.57	-10
CH High-2472	Antenna 1	2489	-50.32	-10
CH High-2472	Antenna 1	2490	-51.72	-10
CH High-2472	Antenna 1	2491	-52.53	-10
CH High-2472	Antenna 1	2492	-53.45	-10
CH High-2472	Antenna 1	2493	-54.17	-10
CH High-2472	Antenna 1	2494	-54.43	-10
CH High-2472	Antenna 1	2495	-54.48	-10
CH High-2472	Antenna 1	2496	-54.37	-10
CH High-2472	Antenna 1	2497.507	-54.54	-20
CH High-2472	Antenna 1	2498.507	-54.87	-20
CH High-2472	Antenna 1	2499.507	-55.1	-20
CH High-2472	Antenna 1	2500.507	-55.3	-20
CH High-2472	Antenna 1	2501.507	-55.61	-20
CH High-2472	Antenna 1	2502.507	-55.83	-20
CH High-2472	Antenna 1	2503.507	-55.95	-20
CH High-2472	Antenna 1	2504.507	-56.01	-20
CH High-2472	Antenna 1	2505.507	-56.1	-20
CH High-2472	Antenna 1	2506.507	-56.17	-20
CH High-2472	Antenna 1	2507.507	-56.51	-20
CH High-2472	Antenna 1	2508.507	-56.39	-20
CH High-2472	Antenna 1	2509.507	-56.48	-20





802.11 g CH Low (Normal Temp, Normal Voltage)

Channel	Antenna	Frequency	Level	Limit
CH Low-2412	Antenna 1	2399.5	-36.62	-10
CH Low-2412	Antenna 1	2398.5	-43.09	-10
CH Low-2412	Antenna 1	2397.5	-48.06	-10
CH Low-2412	Antenna 1	2396.5	-50.84	-10
CH Low-2412	Antenna 1	2395.5	-51.5	-10
CH Low-2412	Antenna 1	2394.5	-53.01	-10
CH Low-2412	Antenna 1	2393.5	-54.05	-10
CH Low-2412	Antenna 1	2392.5	-54.54	-10
CH Low-2412	Antenna 1	2391.5	-54.76	-10
CH Low-2412	Antenna 1	2390.5	-55.16	-10
CH Low-2412	Antenna 1	2389.5	-55.67	-10
CH Low-2412	Antenna 1	2388.5	-56.14	-10
CH Low-2412	Antenna 1	2387.5	-56.45	-10
CH Low-2412	Antenna 1	2386.5	-56.64	-10
CH Low-2412	Antenna 1	2385.5	-56.61	-10
CH Low-2412	Antenna 1	2384.5	-56.87	-10
CH Low-2412	Antenna 1	2382.99	-57.3	-20
CH Low-2412	Antenna 1	2381.99	-57.39	-20
CH Low-2412	Antenna 1	2380.99	-57.48	-20
CH Low-2412	Antenna 1	2379.99	-57.6	-20
CH Low-2412	Antenna 1	2378.99	-57.73	-20
CH Low-2412	Antenna 1	2377.99	-57.91	-20
CH Low-2412	Antenna 1	2376.99	-57.98	-20
CH Low-2412	Antenna 1	2375.99	-58.18	-20
CH Low-2412	Antenna 1	2374.99	-58.03	-20
CH Low-2412	Antenna 1	2373.99	-58.32	-20
CH Low-2412	Antenna 1	2372.99	-58.37	-20
CH Low-2412	Antenna 1	2371.99	-58.31	-20

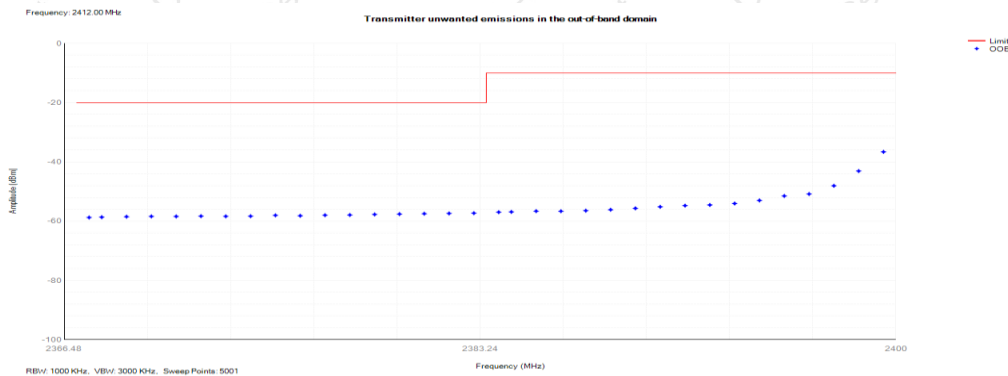



802.11 g CH High (Normal Temp, Normal Voltage)

Channel	Antenna	Frequency	Level	Limit
CH High-2472	Antenna 1	2484	-32.15	-10
CH High-2472	Antenna 1	2485	-37.46	-10
CH High-2472	Antenna 1	2486	-41.75	-10
CH High-2472	Antenna 1	2487	-44.12	-10
CH High-2472	Antenna 1	2488	-44.73	-10
CH High-2472	Antenna 1	2489	-45.59	-10
CH High-2472	Antenna 1	2490	-45.48	-10
CH High-2472	Antenna 1	2491	-46.33	-10
CH High-2472	Antenna 1	2492	-48.81	-10
CH High-2472	Antenna 1	2493	-51.34	-10
CH High-2472	Antenna 1	2494	-53.1	-10
CH High-2472	Antenna 1	2495	-54.85	-10
CH High-2472	Antenna 1	2496	-55.56	-10
CH High-2472	Antenna 1	2500.504	-56.41	-20
CH High-2472	Antenna 1	2501.504	-56.45	-20
CH High-2472	Antenna 1	2502.504	-56.61	-20
CH High-2472	Antenna 1	2503.504	-56.81	-20
CH High-2472	Antenna 1	2504.504	-56.93	-20
CH High-2472	Antenna 1	2505.504	-56.87	-20
CH High-2472	Antenna 1	2506.504	-56.92	-20
CH High-2472	Antenna 1	2507.504	-57.17	-20
CH High-2472	Antenna 1	2508.504	-57.13	-20
CH High-2472	Antenna 1	2509.504	-57.16	-20
CH High-2472	Antenna 1	2510.504	-57.3	-20
CH High-2472	Antenna 1	2511.504	-57.36	-20
CH High-2472	Antenna 1	2512.504	-57.35	-20
CH High-2472	Antenna 1	2513.504	-57.39	-20

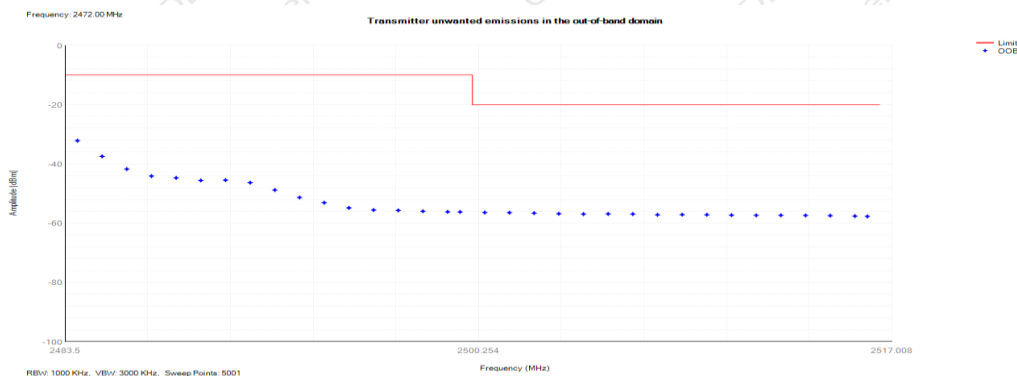



802.11 n20 CH Low (Normal Temp, Normal Voltage)

Channel	Antenna	Frequency	Level	Limit
CH Low-2412	Antenna 1	2399.5	-35.74	-10
CH Low-2412	Antenna 1	2398.5	-41.92	-10
CH Low-2412	Antenna 1	2397.5	-47.77	-10
CH Low-2412	Antenna 1	2396.5	-51.5	-10
CH Low-2412	Antenna 1	2395.5	-53.31	-10
CH Low-2412	Antenna 1	2394.5	-54.19	-10
CH Low-2412	Antenna 1	2393.5	-54.93	-10
CH Low-2412	Antenna 1	2392.5	-55.26	-10
CH Low-2412	Antenna 1	2391.5	-55.55	-10
CH Low-2412	Antenna 1	2390.5	-55.94	-10
CH Low-2412	Antenna 1	2389.5	-56.27	-10
CH Low-2412	Antenna 1	2388.5	-56.63	-10
CH Low-2412	Antenna 1	2387.5	-57	-10
CH Low-2412	Antenna 1	2386.5	-57.17	-10
CH Low-2412	Antenna 1	2385.5	-57.31	-10
CH Low-2412	Antenna 1	2381.808	-57.92	-20
CH Low-2412	Antenna 1	2380.808	-58.05	-20
CH Low-2412	Antenna 1	2379.808	-58.13	-20
CH Low-2412	Antenna 1	2378.808	-58.22	-20
CH Low-2412	Antenna 1	2377.808	-58.38	-20
CH Low-2412	Antenna 1	2376.808	-58.42	-20
CH Low-2412	Antenna 1	2375.808	-58.57	-20
CH Low-2412	Antenna 1	2374.808	-58.62	-20
CH Low-2412	Antenna 1	2373.808	-58.69	-20
CH Low-2412	Antenna 1	2372.808	-58.69	-20
CH Low-2412	Antenna 1	2371.808	-58.81	-20
CH Low-2412	Antenna 1	2370.808	-58.83	-20
CH Low-2412	Antenna 1	2369.808	-58.85	-20

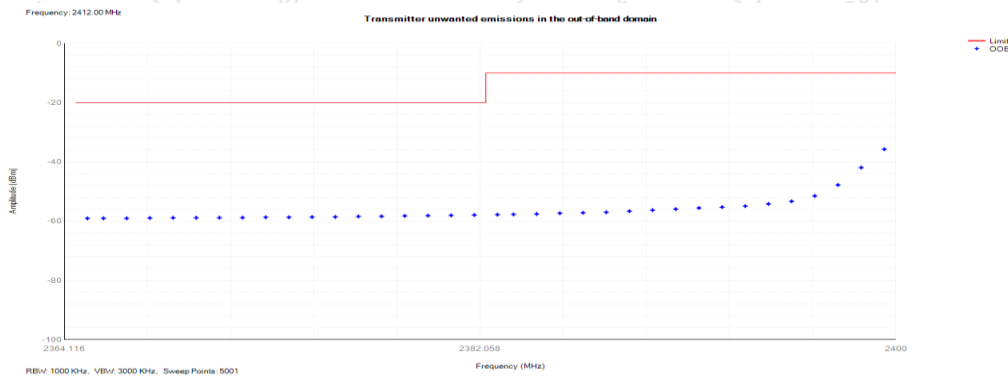



802.11 n20 CH High (Normal Temp, Normal Voltage)

Channel	Antenna	Frequency	Level	Limit
CH High-2472	Antenna 1	2484	-32.04	-10
CH High-2472	Antenna 1	2485	-38.14	-10
CH High-2472	Antenna 1	2486	-43.19	-10
CH High-2472	Antenna 1	2487	-46.02	-10
CH High-2472	Antenna 1	2488	-47.14	-10
CH High-2472	Antenna 1	2489	-48.11	-10
CH High-2472	Antenna 1	2490	-48.24	-10
CH High-2472	Antenna 1	2491	-49.01	-10
CH High-2472	Antenna 1	2492	-50.21	-10
CH High-2472	Antenna 1	2493	-51.57	-10
CH High-2472	Antenna 1	2494	-53.44	-10
CH High-2472	Antenna 1	2495	-54.84	-10
CH High-2472	Antenna 1	2496	-55.84	-10
CH High-2472	Antenna 1	2497	-56.42	-10
CH High-2472	Antenna 1	2498	-56.7	-10
CH High-2472	Antenna 1	2499	-56.84	-10
CH High-2472	Antenna 1	2500	-56.89	-10
CH High-2472	Antenna 1	2501.69	-57.05	-20
CH High-2472	Antenna 1	2502.69	-57.12	-20
CH High-2472	Antenna 1	2503.69	-57.22	-20
CH High-2472	Antenna 1	2504.69	-57.34	-20
CH High-2472	Antenna 1	2505.69	-57.47	-20
CH High-2472	Antenna 1	2506.69	-57.53	-20
CH High-2472	Antenna 1	2507.69	-57.6	-20
CH High-2472	Antenna 1	2508.69	-57.7	-20
CH High-2472	Antenna 1	2509.69	-57.76	-20
CH High-2472	Antenna 1	2510.69	-57.75	-20

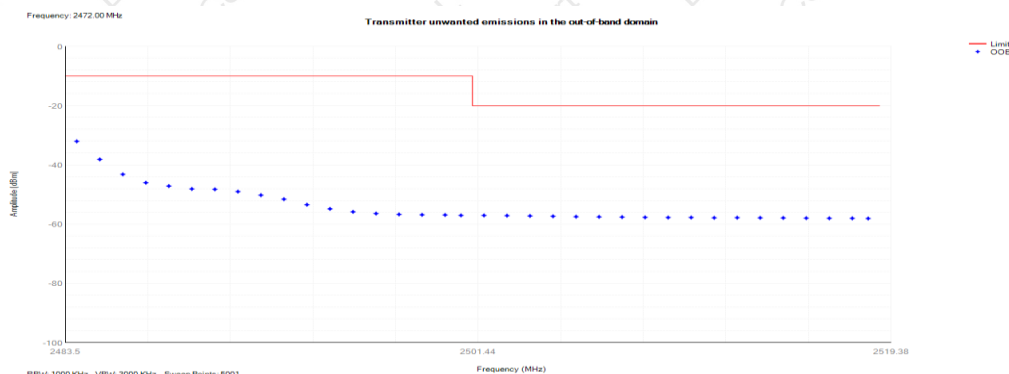

**802.11 n40 CH Low (Normal Temp, Normal Voltage)**

Channel	Antenna	Frequency	Level	Limit
CH Low-2422	Antenna 1	2399.5	-35.15	-10
CH Low-2422	Antenna 1	2398.5	-39.47	-10
CH Low-2422	Antenna 1	2397.5	-43.98	-10
CH Low-2422	Antenna 1	2396.5	-48.34	-10
CH Low-2422	Antenna 1	2395.5	-51.25	-10
CH Low-2422	Antenna 1	2394.5	-52.68	-10
CH Low-2422	Antenna 1	2393.5	-53.18	-10
CH Low-2422	Antenna 1	2392.5	-53.45	-10
CH Low-2422	Antenna 1	2391.5	-53.59	-10
CH Low-2422	Antenna 1	2390.5	-53.79	-10
CH Low-2422	Antenna 1	2389.5	-53.26	-10
CH Low-2422	Antenna 1	2388.5	-53.95	-10
CH Low-2422	Antenna 1	2387.5	-54.66	-10
CH Low-2422	Antenna 1	2386.5	-54.3	-10
CH Low-2422	Antenna 1	2385.5	-55.21	-10
CH Low-2422	Antenna 1	2384.5	-55.38	-10
CH Low-2422	Antenna 1	2383.5	-56.11	-10
CH Low-2422	Antenna 1	2382.5	-56.26	-10
CH Low-2422	Antenna 1	2381.5	-56.66	-10
CH Low-2422	Antenna 1	2380.5	-56.61	-10
CH Low-2422	Antenna 1	2379.5	-56.72	-10
CH Low-2422	Antenna 1	2378.5	-57.01	-10
CH Low-2422	Antenna 1	2377.5	-57.31	-10
CH Low-2422	Antenna 1	2376.5	-57.41	-10
CH Low-2422	Antenna 1	2375.5	-57.54	-10
CH Low-2422	Antenna 1	2374.5	-57.56	-10
CH Low-2422	Antenna 1	2373.5	-57.8	-10
CH Low-2422	Antenna 1	2372.5	-57.97	-10
CH Low-2422	Antenna 1	2371.5	-57.97	-10
CH Low-2422	Antenna 1	2370.5	-58.34	-10
CH Low-2422	Antenna 1	2369.5	-58.19	-10
CH Low-2422	Antenna 1	2368.5	-58.47	-10
CH Low-2422	Antenna 1	2367.5	-58.67	-10
CH Low-2422	Antenna 1	2366.5	-58.64	-10
CH Low-2422	Antenna 1	2365.5	-58.7	-10
CH Low-2422	Antenna 1	2363.26	-58.89	-20



CH Low-2422	Antenna 1	2362.26	-58.97	-20
CH Low-2422	Antenna 1	2361.26	-58.99	-20
CH Low-2422	Antenna 1	2360.26	-58.98	-20
CH Low-2422	Antenna 1	2359.26	-59.07	-20
CH Low-2422	Antenna 1	2358.26	-59.18	-20
CH Low-2422	Antenna 1	2357.26	-59.12	-20
CH Low-2422	Antenna 1	2356.26	-59.28	-20
CH Low-2422	Antenna 1	2355.26	-59.27	-20
CH Low-2422	Antenna 1	2354.26	-59.35	-20
CH Low-2422	Antenna 1	2353.26	-59.31	-20
CH Low-2422	Antenna 1	2352.26	-59.36	-20
CH Low-2422	Antenna 1	2351.26	-59.5	-20
CH Low-2422	Antenna 1	2350.26	-59.51	-20
CH Low-2422	Antenna 1	2349.26	-59.59	-20
CH Low-2422	Antenna 1	2348.26	-59.55	-20
CH Low-2422	Antenna 1	2347.26	-59.6	-20
CH Low-2422	Antenna 1	2346.26	-59.64	-20
CH Low-2422	Antenna 1	2345.26	-59.7	-20
CH Low-2422	Antenna 1	2344.26	-59.61	-20
CH Low-2422	Antenna 1	2343.26	-59.67	-20
CH Low-2422	Antenna 1	2342.26	-59.71	-20
CH Low-2422	Antenna 1	2341.26	-59.64	-20
CH Low-2422	Antenna 1	2340.26	-59.68	-20
CH Low-2422	Antenna 1	2339.26	-59.74	-20
CH Low-2422	Antenna 1	2338.26	-59.81	-20
CH Low-2422	Antenna 1	2337.26	-59.77	-20

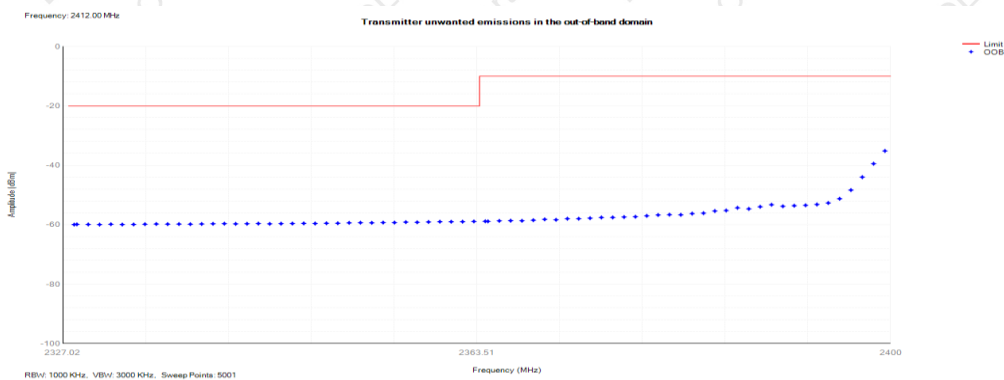

**802.11 n40 CH High (Normal Temp, Normal Voltage)**

Channel	Antenna	Frequency	Level	Limit
CH High-2462	Antenna 1	2484	-31.4	-10
CH High-2462	Antenna 1	2485	-36.03	-10
CH High-2462	Antenna 1	2486	-39.99	-10
CH High-2462	Antenna 1	2487	-43.4	-10
CH High-2462	Antenna 1	2488	-45.38	-10
CH High-2462	Antenna 1	2489	-45.42	-10
CH High-2462	Antenna 1	2490	-45.97	-10
CH High-2462	Antenna 1	2491	-46.63	-10
CH High-2462	Antenna 1	2492	-47.95	-10
CH High-2462	Antenna 1	2493	-47.98	-10
CH High-2462	Antenna 1	2494	-48.6	-10
CH High-2462	Antenna 1	2495	-49.03	-10
CH High-2462	Antenna 1	2496	-48.38	-10
CH High-2462	Antenna 1	2497	-48.16	-10
CH High-2462	Antenna 1	2498	-47.33	-10
CH High-2462	Antenna 1	2499	-48.02	-10
CH High-2462	Antenna 1	2500	-48.55	-10
CH High-2462	Antenna 1	2501	-49.82	-10
CH High-2462	Antenna 1	2502	-50.62	-10
CH High-2462	Antenna 1	2503	-51.8	-10
CH High-2462	Antenna 1	2504	-52.08	-10
CH High-2462	Antenna 1	2505	-52.03	-10
CH High-2462	Antenna 1	2506	-53.01	-10
CH High-2462	Antenna 1	2507	-53.36	-10
CH High-2462	Antenna 1	2508	-54.22	-10
CH High-2462	Antenna 1	2509	-54.81	-10
CH High-2462	Antenna 1	2510	-55.3	-10
CH High-2462	Antenna 1	2511	-55.84	-10
CH High-2462	Antenna 1	2512	-56.39	-10
CH High-2462	Antenna 1	2513	-56.97	-10
CH High-2462	Antenna 1	2514	-57.35	-10
CH High-2462	Antenna 1	2515	-57.7	-10
CH High-2462	Antenna 1	2520.244	-57.89	-20
CH High-2462	Antenna 1	2521.244	-57.94	-20
CH High-2462	Antenna 1	2522.244	-58.06	-20



CH High-2462	Antenna 1	2523.244	-58.09	-20
CH High-2462	Antenna 1	2524.244	-58.13	-20
CH High-2462	Antenna 1	2525.244	-58.15	-20
CH High-2462	Antenna 1	2526.244	-58.21	-20
CH High-2462	Antenna 1	2527.244	-58.15	-20
CH High-2462	Antenna 1	2528.244	-58.19	-20
CH High-2462	Antenna 1	2529.244	-58.13	-20
CH High-2462	Antenna 1	2530.244	-58.18	-20
CH High-2462	Antenna 1	2531.244	-58.19	-20
CH High-2462	Antenna 1	2532.244	-58.3	-20
CH High-2462	Antenna 1	2533.244	-58.21	-20
CH High-2462	Antenna 1	2534.244	-58.24	-20
CH High-2462	Antenna 1	2535.244	-58.26	-20
CH High-2462	Antenna 1	2536.244	-58.33	-20
CH High-2462	Antenna 1	2537.244	-58.22	-20
CH High-2462	Antenna 1	2538.244	-58.28	-20
CH High-2462	Antenna 1	2539.244	-58.29	-20
CH High-2462	Antenna 1	2540.244	-58.28	-20
CH High-2462	Antenna 1	2541.244	-58.35	-20
CH High-2462	Antenna 1	2542.244	-58.11	-20
CH High-2462	Antenna 1	2543.244	-58.39	-20
CH High-2462	Antenna 1	2544.244	-58.34	-20
CH High-2462	Antenna 1	2545.244	-58.34	-20
CH High-2462	Antenna 1	2546.244	-58.35	-20
CH High-2462	Antenna 1	2547.244	-58.42	-20
CH High-2462	Antenna 1	2548.244	-58.45	-20

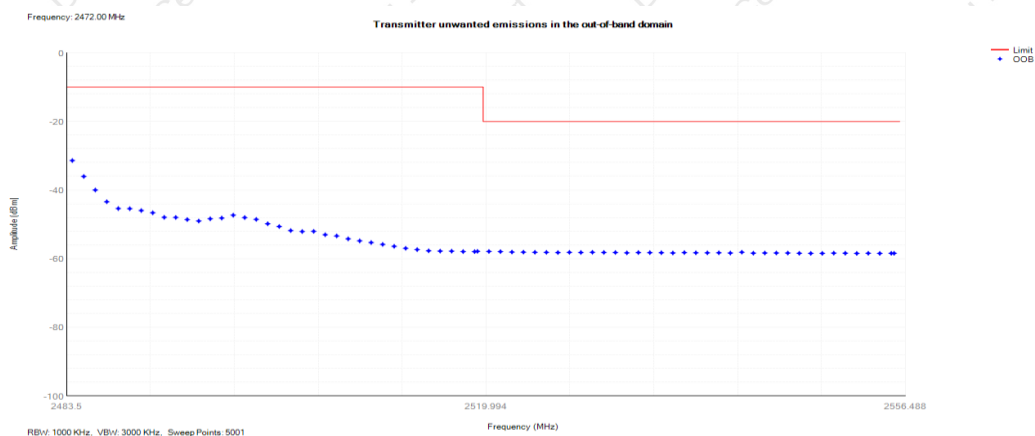

10. TRANSMITTER UNWANTED EMISSIONS IN THE SPURIOUS DOMAIN

10.1 Block Diagram of Test Setup

Below 1GHz

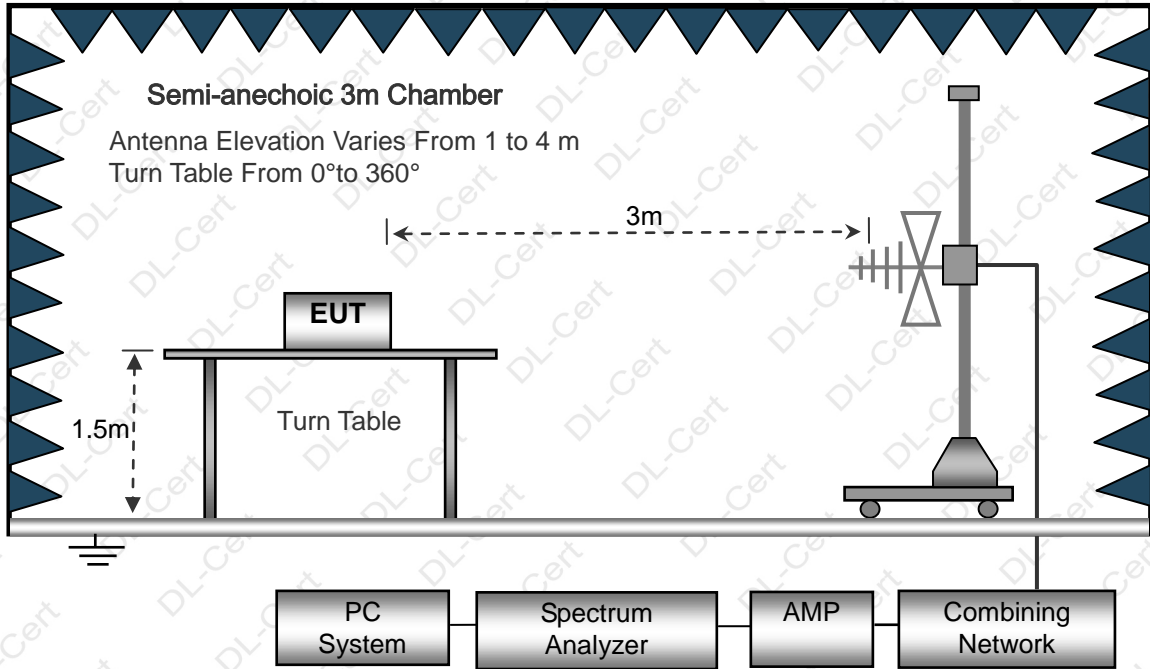

Above 1GHz

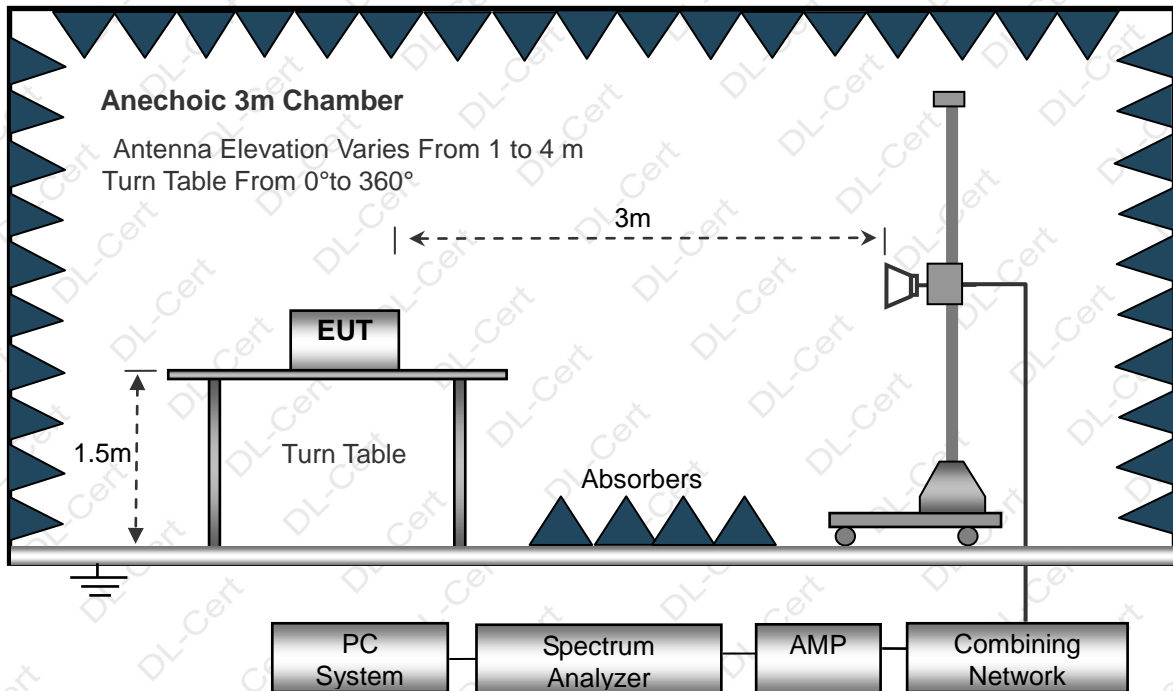



10.2 Limit

The transmitter unwanted emissions in the spurious domain shall not exceed the values given in table 12.

Table 12: Transmitter limits for spurious emissions

Frequency range	Maximum power	Bandwidth
30 MHz to 47 MHz	-36 dBm	100 kHz
47 MHz to 74 MHz	-54 dBm	100 kHz
74 MHz to 87,5 MHz	-36 dBm	100 kHz
87,5 MHz to 118 MHz	-54 dBm	100 kHz
118 MHz to 174 MHz	-36 dBm	100 kHz
174 MHz to 230 MHz	-54 dBm	100 kHz
230 MHz to 470 MHz	-36 dBm	100 kHz
470 MHz to 694 MHz	-54 dBm	100 kHz
694 MHz to 1 GHz	-36 dBm	100 kHz
1 GHz to 12,75 GHz	-30 dBm	1 MHz

10.3 Test Procedure

Refer to ETSI EN 300 328 V2.2.0 Clause 5.4.9.

10.4 Test Result

Below 1GHz

Spurious Emission Test Data					
Frequency (MHz)	Polarization	Level (dBm)	Limit (dBm)	Marging (dB)	Result
31.78	Vertical	-63.29	-36	-27.29	Pass
52.92	Vertical	-64.32	-54	-10.32	Pass
174.02	Vertical	-63.23	-54	-9.23	Pass
214.30	Vertical	-63.28	-54	-9.28	Pass
452.54	Vertical	-61.29	-36	-25.29	Pass
773.02	Vertical	-63.92	-36	-27.92	Pass
39.91	Horizontal	-63.54	-36	-27.54	Pass
115.07	Horizontal	-62.91	-54	-8.91	Pass
289.08	Horizontal	-63.11	-36	-27.11	Pass
452.54	Horizontal	-64.29	-36	-28.29	Pass
555.62	Horizontal	-60.93	-54	-6.93	Pass
660.50	Horizontal	-62.09	-54	-8.09	Pass



Above 1GHz

Spurious Emission Test Data						
Mode	Frequency (MHz)	Polarization	Level (dBm)	Limit (dBm)	Margin (dB)	Result
802.11b Low Channel	4824	Vertical	-42.47	-30.00	-12.47	Pass
	7236	Vertical	-45.02	-30.00	-15.02	Pass
	9648	Vertical	-47.93	-30.00	-17.93	Pass
	4824	Horizontal	-42.70	-30.00	-12.70	Pass
	7236	Horizontal	-46.34	-30.00	-16.34	Pass
	9648	Horizontal	-48.58	-30.00	-18.58	Pass
802.11b Middle Channel	4884	Vertical	-42.40	-30.00	-12.40	Pass
	7326	Vertical	-44.49	-30.00	-14.49	Pass
	9768	Vertical	-49.55	-30.00	-19.55	Pass
	4884	Horizontal	-41.58	-30.00	-11.58	Pass
	7326	Horizontal	-45.67	-30.00	-15.67	Pass
	9768	Horizontal	-48.70	-30.00	-18.70	Pass
802.11b High Channel	4944	Vertical	-41.97	-30.00	-11.97	Pass
	7416	Vertical	-43.85	-30.00	-13.85	Pass
	9888	Vertical	-47.32	-30.00	-17.32	Pass
	4944	Horizontal	-41.94	-30.00	-11.94	Pass
	7416	Horizontal	-45.14	-30.00	-15.14	Pass
	9888	Horizontal	-48.81	-30.00	-18.81	Pass
802.11g Low Channel	4824	Vertical	-42.05	-30.00	-12.05	Pass
	7236	Vertical	-45.02	-30.00	-15.02	Pass
	9648	Vertical	-47.93	-30.00	-17.93	Pass
	4824	Horizontal	-42.70	-30.00	-12.70	Pass
	7236	Horizontal	-46.34	-30.00	-16.34	Pass
	9648	Horizontal	-48.58	-30.00	-18.58	Pass
802.11g Middle Channel	4884	Vertical	-43.01	-30.00	-13.01	Pass
	7326	Vertical	-46.75	-30.00	-16.75	Pass
	9768	Vertical	-49.77	-30.00	-19.77	Pass
	4884	Horizontal	-43.12	-30.00	-13.12	Pass
	7326	Horizontal	-45.89	-30.00	-15.89	Pass
	9768	Horizontal	-50.57	-30.00	-20.57	Pass
802.11g High Channel	4944	Vertical	-43.84	-30.00	-13.84	Pass
	7416	Vertical	-46.02	-30.00	-16.02	Pass
	9888	Vertical	-50.54	-30.00	-20.54	Pass
	4944	Horizontal	-42.72	-30.00	-12.72	Pass
	7416	Horizontal	-46.75	-30.00	-16.75	Pass
	9888	Horizontal	-51.41	-30.00	-21.41	Pass



Spurious Emission Test Data						
Mode	Frequency (MHz)	Polarization	Level (dBm)	Limit (dBm)	Margin (dB)	Result
802.11n HT20 Low Channel	4824	Vertical	-42.22	-30.00	-12.22	Pass
	7236	Vertical	-44.75	-30.00	-14.75	Pass
	9648	Vertical	-47.63	-30.00	-17.63	Pass
	4824	Horizontal	-42.43	-30.00	-12.43	Pass
	7236	Horizontal	-46.06	-30.00	-16.06	Pass
	9648	Horizontal	-48.28	-30.00	-18.28	Pass
802.11n HT20 Middle Channel	4884	Vertical	-42.15	-30.00	-12.15	Pass
	7326	Vertical	-44.22	-30.00	-14.22	Pass
	9768	Vertical	-49.25	-30.00	-19.25	Pass
	4884	Horizontal	-41.34	-30.00	-11.34	Pass
	7326	Horizontal	-45.40	-30.00	-15.40	Pass
	9768	Horizontal	-48.40	-30.00	-18.40	Pass
802.11n HT20 High Channel	4944	Vertical	-41.72	-30.00	-11.72	Pass
	7416	Vertical	-43.58	-30.00	-13.58	Pass
	9888	Vertical	-47.04	-30.00	-17.04	Pass
	4944	Horizontal	-41.69	-30.00	-11.69	Pass
	7416	Horizontal	-44.86	-30.00	-14.86	Pass
	9888	Horizontal	-48.51	-30.00	-18.51	Pass
802.11n HT40 Low Channel	4844	Vertical	-42.35	-30.00	-12.35	Pass
	7266	Vertical	-44.89	-30.00	-14.89	Pass
	9688	Vertical	-47.79	-30.00	-17.79	Pass
	4844	Horizontal	-42.57	-30.00	-12.57	Pass
	7266	Horizontal	-46.20	-30.00	-16.20	Pass
	9688	Horizontal	-48.44	-30.00	-18.44	Pass
802.11n HT40 Middle Channel	4884	Vertical	-42.88	-30.00	-12.88	Pass
	7326	Vertical	-46.61	-30.00	-16.61	Pass
	9768	Vertical	-49.62	-30.00	-19.62	Pass
	4884	Horizontal	-42.99	-30.00	-12.99	Pass
	7326	Horizontal	-45.75	-30.00	-15.75	Pass
	9768	Horizontal	-50.42	-30.00	-20.42	Pass
802.11n HT40 High Channel	4904	Vertical	-43.72	-30.00	-13.72	Pass
	7356	Vertical	-45.88	-30.00	-15.88	Pass
	9808	Vertical	-50.40	-30.00	-20.40	Pass
	4904	Horizontal	-42.59	-30.00	-12.59	Pass
	7356	Horizontal	-46.61	-30.00	-16.61	Pass
	9808	Horizontal	-51.27	-30.00	-21.27	Pass

11. RECEIVER SPURIOUS EMISSIONS

11.1 Block Diagram of Test Setup

Below 1GHz

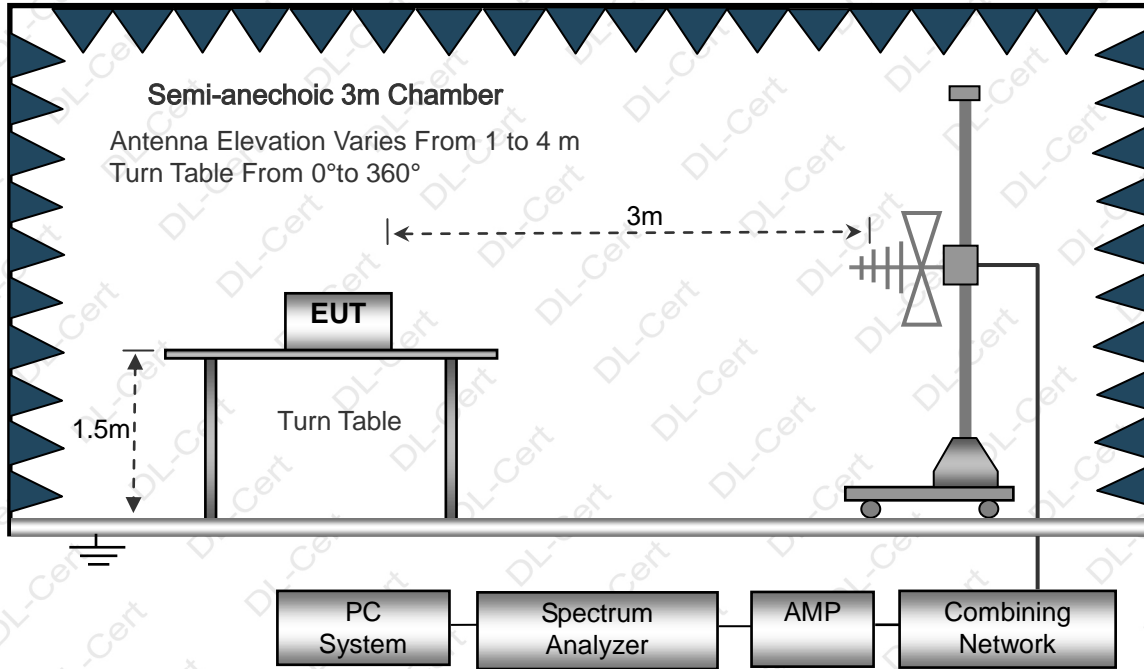

Above 1GHz

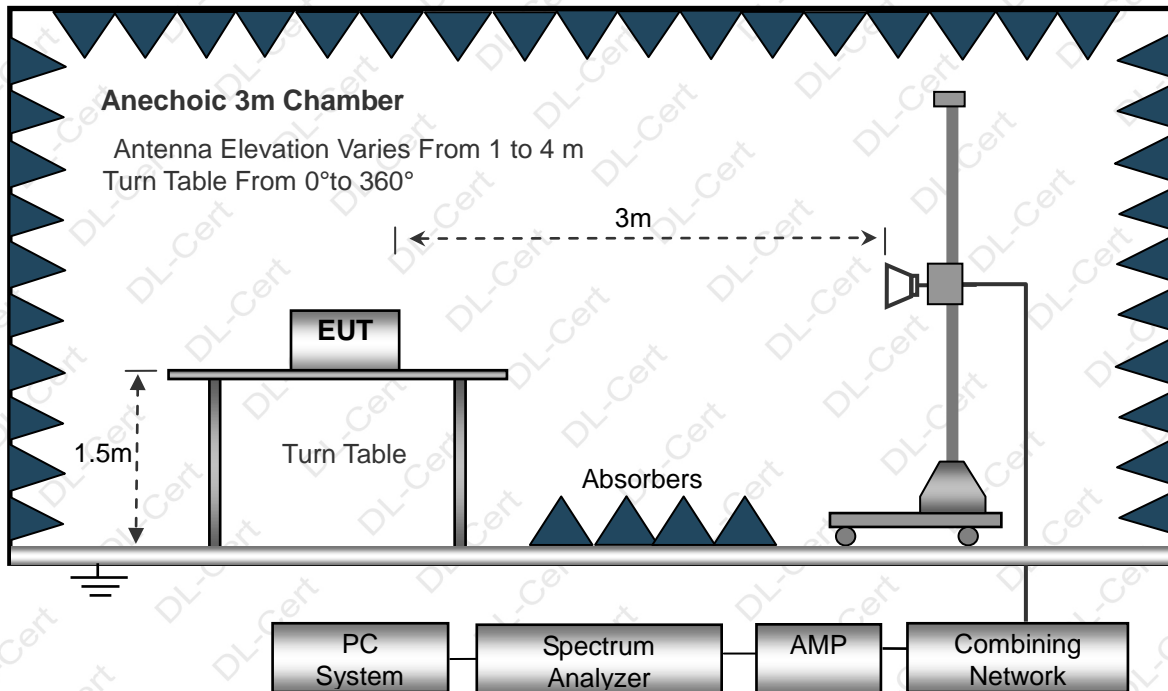



11.2 Limit

The spurious emissions of the receiver shall not exceed the values given in table 13.

Table 13: Spurious emission limits for receivers

Frequency range	Maximum power	Bandwidth
30 MHz to 1 GHz	-57 dBm	100 kHz
1 GHz to 12,75 GHz	-47 dBm	1 MHz

11.3 Test Procedure

Refer to ETSI EN 300 328 V2.2.0 Clause 5.4.9.

11.4 Test Result

Below 1GHz

Receiver spurious emissions Test Data					
Frequency (MHz)	Polarization	Level (dBm)	Limit (dBm)	Marging (dB)	Result
32.07	Vertical	-68.29	-57.00	-11.29	Pass
53.95	Vertical	-69.32	-57.00	-12.32	Pass
177.41	Vertical	-69.23	-57.00	-12.23	Pass
218.48	Vertical	-69.28	-57.00	-12.28	Pass
461.36	Vertical	-69.23	-57.00	-12.23	Pass
788.08	Vertical	-68.92	-57.00	-11.92	Pass
40.69	Horizontal	-69.54	-57.00	-12.54	Pass
117.32	Horizontal	-68.91	-57.00	-11.91	Pass
294.72	Horizontal	-69.11	-57.00	-12.11	Pass
461.36	Horizontal	-70.29	-57.00	-13.29	Pass
566.45	Horizontal	-70.93	-57.00	-13.93	Pass
673.37	Horizontal	-72.09	-57.00	-15.09	Pass



Above 1GHz

Receiver spurious emissions Test Data						
Mode	Frequency (MHz)	Polarization	Level (dBm)	Limit (dBm)	Margin (dB)	Result
802.11b Low Channel	4824	Vertical	-51.40	-47.00	-4.40	Pass
	7236	Vertical	-51.33	-47.00	-4.33	Pass
	9648	Vertical	-57.95	-47.00	-10.95	Pass
	4824	Horizontal	-50.78	-47.00	-3.78	Pass
	7236	Horizontal	-57.40	-47.00	-10.40	Pass
	9648	Horizontal	-56.80	-47.00	-9.80	Pass
802.11b Middle Channel	4884	Vertical	-55.30	-47.00	-8.30	Pass
	7326	Vertical	-55.40	-47.00	-8.40	Pass
	9768	Vertical	-51.11	-47.00	-4.11	Pass
	4884	Horizontal	-51.07	-47.00	-4.07	Pass
	7326	Horizontal	-56.54	-47.00	-9.54	Pass
	9768	Horizontal	-57.90	-47.00	-10.90	Pass
802.11b High Channel	4944	Vertical	-55.96	-47.00	-8.96	Pass
	7416	Vertical	-57.16	-47.00	-10.16	Pass
	9888	Vertical	-53.77	-47.00	-6.77	Pass
	4944	Horizontal	-53.25	-47.00	-6.25	Pass
	7416	Horizontal	-53.04	-47.00	-6.04	Pass
	9888	Horizontal	-55.07	-47.00	-8.07	Pass
802.11g Low Channel	4824	Vertical	-51.24	-47.00	-4.24	Pass
	7236	Vertical	-50.72	-47.00	-3.72	Pass
	9648	Vertical	-56.59	-47.00	-9.59	Pass
	4824	Horizontal	-53.72	-47.00	-6.72	Pass
	7236	Horizontal	-53.12	-47.00	-6.12	Pass
	9648	Horizontal	-52.94	-47.00	-5.94	Pass
802.11g Middle Channel	4884	Vertical	-57.48	-47.00	-10.48	Pass
	7326	Vertical	-55.64	-47.00	-8.64	Pass
	9768	Vertical	-51.03	-47.00	-4.03	Pass
	4884	Horizontal	-54.88	-47.00	-7.88	Pass
	7326	Horizontal	-51.31	-47.00	-4.31	Pass
	9768	Horizontal	-53.34	-47.00	-6.34	Pass
802.11g High Channel	4944	Vertical	-56.75	-47.00	-9.75	Pass
	7416	Vertical	-52.92	-47.00	-5.92	Pass
	9888	Vertical	-53.02	-47.00	-6.02	Pass
	4944	Horizontal	-55.60	-47.00	-8.60	Pass
	7416	Horizontal	-52.82	-47.00	-5.82	Pass
	9888	Horizontal	-52.45	-47.00	-5.45	Pass



Receiver spurious emissions Test Data						
Mode	Frequency (MHz)	Polarization	Level (dBm)	Limit (dBm)	Margin (dB)	Result
802.11n HT20 Low Channel	4824	Vertical	-58.07	-47.00	-11.07	Pass
	7236	Vertical	-51.76	-47.00	-4.76	Pass
	9648	Vertical	-52.72	-47.00	-5.72	Pass
	4824	Horizontal	-53.58	-47.00	-6.58	Pass
	7236	Horizontal	-50.59	-47.00	-3.59	Pass
	9648	Horizontal	-51.70	-47.00	-4.70	Pass
802.11n HT20 Middle Channel	4884	Vertical	-56.39	-47.00	-9.39	Pass
	7326	Vertical	-53.69	-47.00	-6.69	Pass
	9768	Vertical	-55.94	-47.00	-8.94	Pass
	4884	Horizontal	-56.19	-47.00	-9.19	Pass
	7326	Horizontal	-56.64	-47.00	-9.64	Pass
	9768	Horizontal	-57.27	-47.00	-10.27	Pass
802.11n HT20 High Channel	4944	Vertical	-53.00	-47.00	-6.00	Pass
	7416	Vertical	-54.26	-47.00	-7.26	Pass
	9888	Vertical	-53.25	-47.00	-6.25	Pass
	4944	Horizontal	-54.07	-47.00	-7.07	Pass
	7416	Horizontal	-54.68	-47.00	-7.68	Pass
	9888	Horizontal	-52.79	-47.00	-5.79	Pass
802.11n HT40 Low Channel	4844	Vertical	-55.26	-47.00	-8.26	Pass
	7266	Vertical	-55.20	-47.00	-8.20	Pass
	9688	Vertical	-51.07	-47.00	-4.07	Pass
	4844	Horizontal	-51.35	-47.00	-4.35	Pass
	7266	Horizontal	-55.33	-47.00	-8.33	Pass
	9688	Horizontal	-52.92	-47.00	-5.92	Pass
802.11n HT40 Middle Channel	4884	Vertical	-52.29	-47.00	-5.29	Pass
	7326	Vertical	-51.33	-47.00	-4.33	Pass
	9768	Vertical	-53.03	-47.00	-6.03	Pass
	4884	Horizontal	-57.13	-47.00	-10.13	Pass
	7326	Horizontal	-54.66	-47.00	-7.66	Pass
	9768	Horizontal	-58.05	-47.00	-11.05	Pass
802.11n HT40 High Channel	4904	Vertical	-53.91	-47.00	-6.91	Pass
	7356	Vertical	-58.06	-47.00	-11.06	Pass
	9808	Vertical	-55.61	-47.00	-8.61	Pass
	4904	Horizontal	-55.52	-47.00	-8.52	Pass
	7356	Horizontal	-54.68	-47.00	-7.68	Pass
	9808	Horizontal	-54.22	-47.00	-7.22	Pass



12. RECEIVER BLOCKING

12.1 Block Diagram of Test Setup

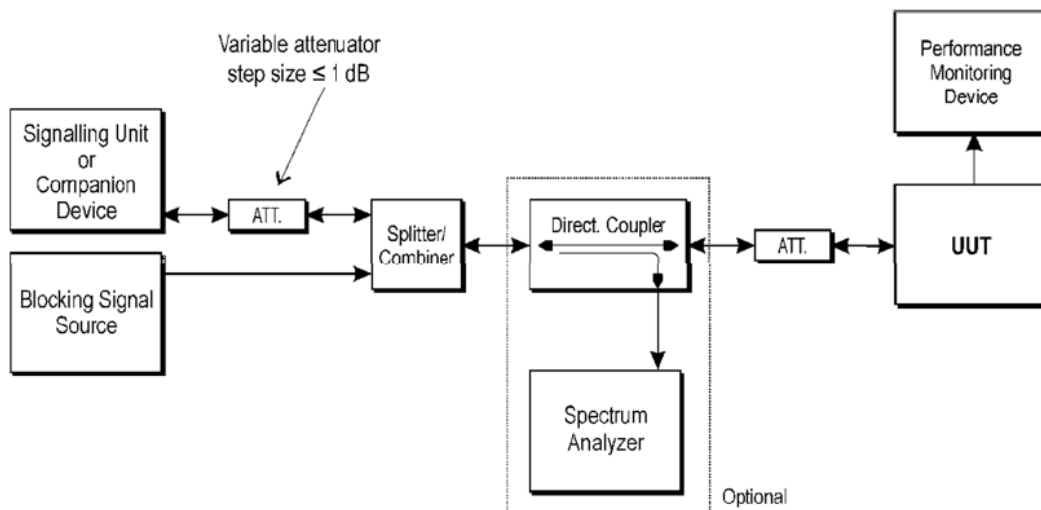

12.2 Limit

Table 14 contains the Receiver Blocking parameters for Receiver Category 1 equipment.

Table 14: Receiver Blocking parameters for Receiver Category 1 equipment

Wanted signal mean power from companion device (dBm) (see notes 1 and 4)	Blocking signal frequency (MHz)	Blocking signal power (dBm) (see note 4)	Type of blocking signal
$(-133 \text{ dBm} + 10 \times \log_{10}(\text{OCBW}))$ or -68 dBm whichever is less (see note 2)	2 380 2 504	-34	CW
$(-139 \text{ dBm} + 10 \times \log_{10}(\text{OCBW}))$ or -74 dBm whichever is less (see note 3)	2 300 2 330 2 360 2 524 2 584 2 674		
NOTE 1: OCBW is in Hz.			
NOTE 2: In case of radiated measurements using a companion device and the level of the wanted signal from the companion device cannot be determined, a relative test may be performed using a wanted signal up to $P_{\text{min}} + 26 \text{ dB}$ where P_{min} is the minimum level of wanted signal required to meet the minimum performance criteria as defined in clause 4.3.1.12.3 in the absence of any blocking signal.			
NOTE 3: In case of radiated measurements using a companion device and the level of the wanted signal from the companion device cannot be determined, a relative test may be performed using a wanted signal up to $P_{\text{min}} + 20 \text{ dB}$ where P_{min} is the minimum level of wanted signal required to meet the minimum performance criteria as defined in clause 4.3.1.12.3 in the absence of any blocking signal.			
NOTE 4: The level specified is the level at the UUT receiver input assuming a 0 dBi antenna assembly gain. In case of conducted measurements, this level has to be corrected for the (in-band) antenna assembly gain (G). In case of radiated measurements, this level is equivalent to a power flux density (PFD) in front of the UUT antenna with the UUT being configured/positioned as recorded in clause 5.4.3.2.2.			



Table 15 contains the Receiver Blocking parameters for Receiver Category 2 equipment.

Table 15: Receiver Blocking parameters receiver Category 2 equipment

Wanted signal mean power from companion device (dBm) (see notes 1 and 3)	Blocking signal frequency (MHz)	Blocking signal power (dBm) (see note 3)	Type of blocking signal
$(-139 \text{ dBm} + 10 \times \log_{10}(\text{OCBW}) + 10 \text{ dB})$ or $(-74 \text{ dBm} + 10 \text{ dB})$ whichever is less (see note 2)	2 380 2 504 2 300 2 584	-34	CW
NOTE 1: OCBW is in Hz. NOTE 2: In case of radiated measurements using a companion device and the level of the wanted signal from the companion device cannot be determined, a relative test may be performed using a wanted signal up to $P_{\min} + 26 \text{ dB}$ where P_{\min} is the minimum level of wanted signal required to meet the minimum performance criteria as defined in clause 4.3.1.12.3 in the absence of any blocking signal. NOTE 3: The level specified is the level at the UUT receiver input assuming a 0 dBi antenna assembly gain. In case of conducted measurements, this level has to be corrected for the (in-band) antenna assembly gain (G). In case of radiated measurements, this level is equivalent to a power flux density (PFD) in front of the UUT antenna with the UUT being configured/positioned as recorded in clause 5.4.3.2.2.			

Table 16 contains the Receiver Blocking parameters for Receiver Category 3 equipment.

Table 16: Receiver Blocking parameters receiver Category 3 equipment

Wanted signal mean power from companion device (dBm) (see notes 1 and 3)	Blocking signal frequency (MHz)	Blocking signal power (dBm) (see note 3)	Type of blocking signal
$(-139 \text{ dBm} + 10 \times \log_{10}(\text{OCBW}) + 20 \text{ dB})$ or $(-74 \text{ dBm} + 20 \text{ dB})$ whichever is less (see note 2)	2 380 2 504 2 300 2 584	-34	CW
NOTE 1: OCBW is in Hz. NOTE 2: In case of radiated measurements using a companion device and the level of the wanted signal from the companion device cannot be determined, a relative test may be performed using a wanted signal up to $P_{\min} + 30 \text{ dB}$ where P_{\min} is the minimum level of wanted signal required to meet the minimum performance criteria as defined in clause 4.3.1.12.3 in the absence of any blocking signal. NOTE 3: The level specified is the level at the UUT receiver input assuming a 0 dBi antenna assembly gain. In case of conducted measurements, this level has to be corrected for the (in-band) antenna assembly gain (G). In case of radiated measurements, this level is equivalent to a power flux density (PFD) in front of the UUT antenna with the UUT being configured/positioned as recorded in clause 5.4.3.2.2.			

12.3 Test Procedure

Refer to ETSI EN 300 328 V2.2.0 Clause 5.4.11.

12.4 Test Results

PASS

Observation Result: Refer to 5 that blocking signal is injected while interference signal is present. With the presence of the blocking signal, channel of the observation does not resume the link.



13. GEO-LOCATION CAPABILITY

13.1 Definition and Requirements

Geo-location capability is a feature of the equipment to determine its geographical location with the purpose to configure itself according to the regulatory requirements applicable at the geographical location where it operates.

The geo-location capability may be present in the equipment or in an external device (temporary) associated with the equipment operating at the same geographical location during the initial power up of the equipment. The geographical location may also be available in equipment already installed and operating at the same geographical location.

13.2 Test Results

This product doesn't support Geo-location.



14. SETUP PHOTOGRAPHS

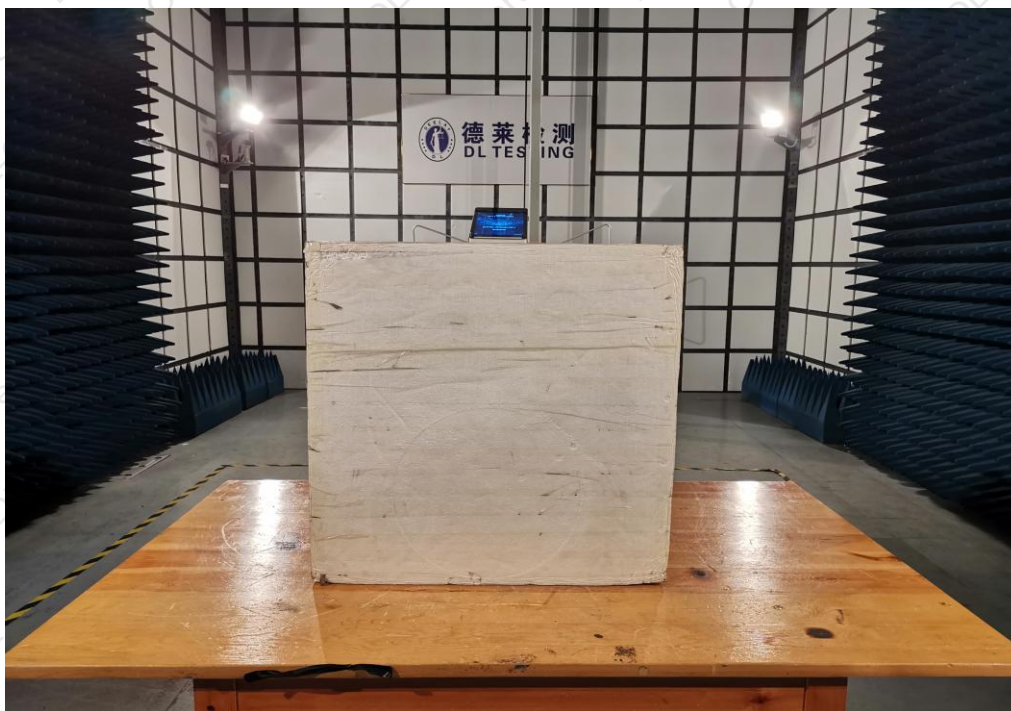



15. EUT PHOTOGRAPHS



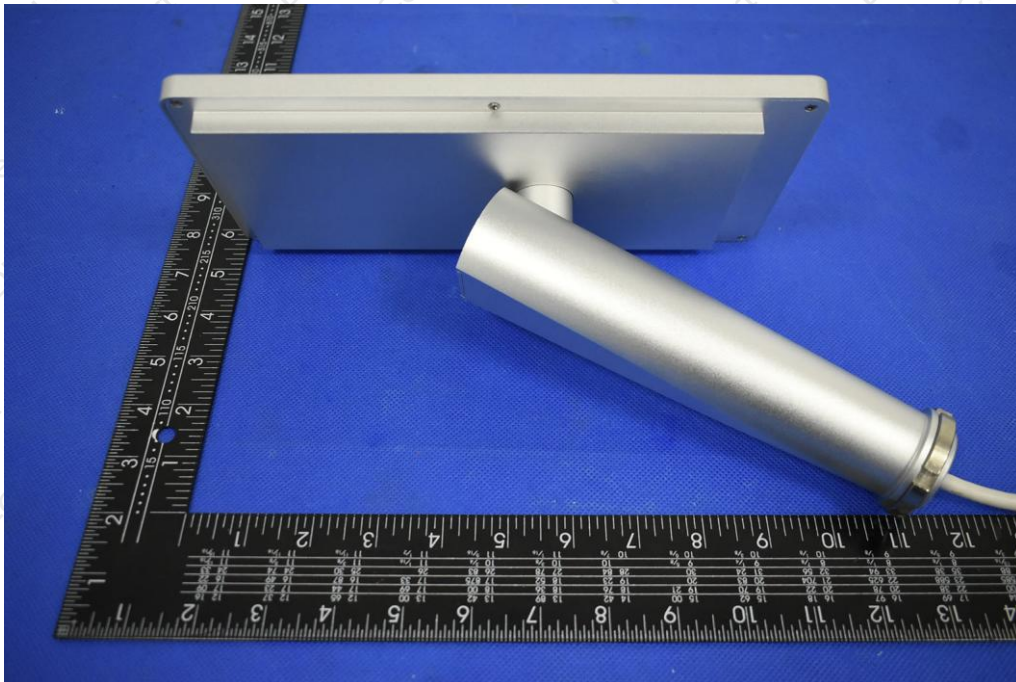

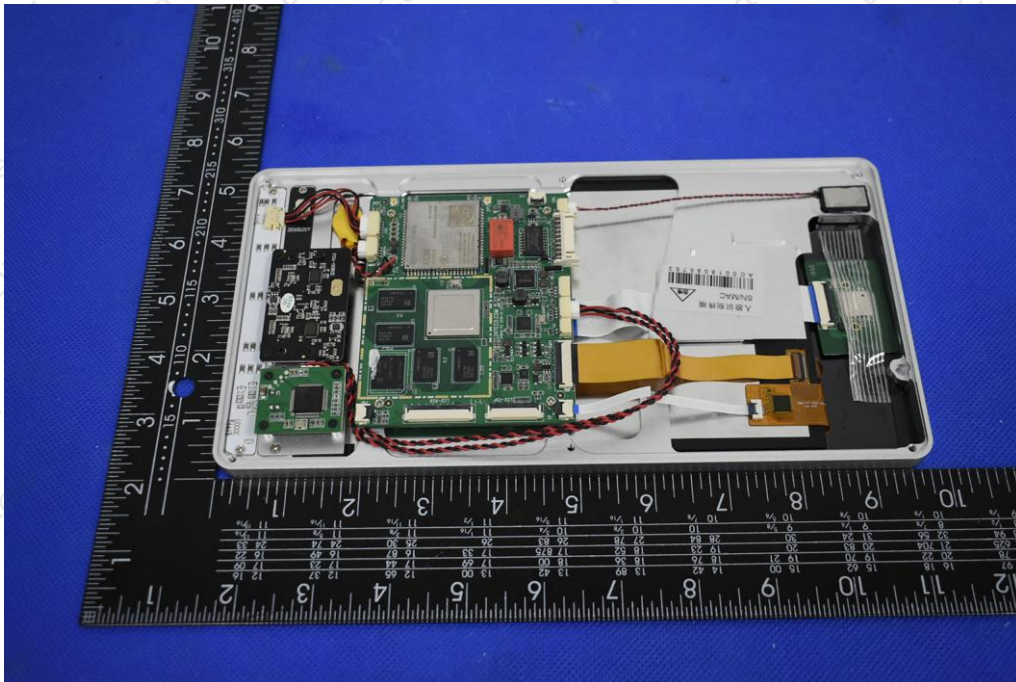
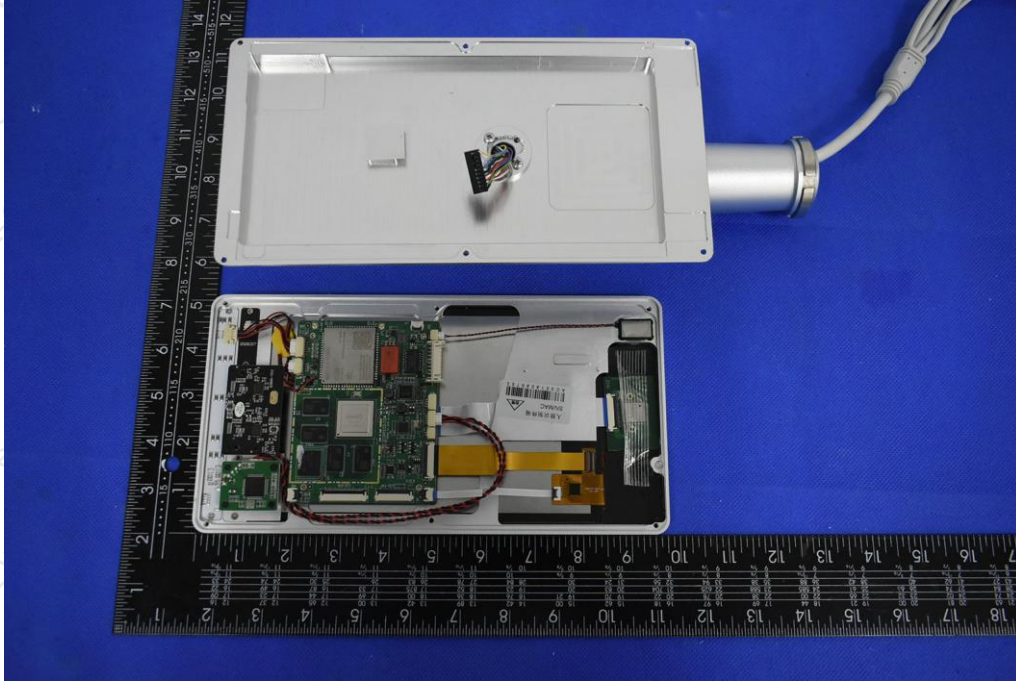

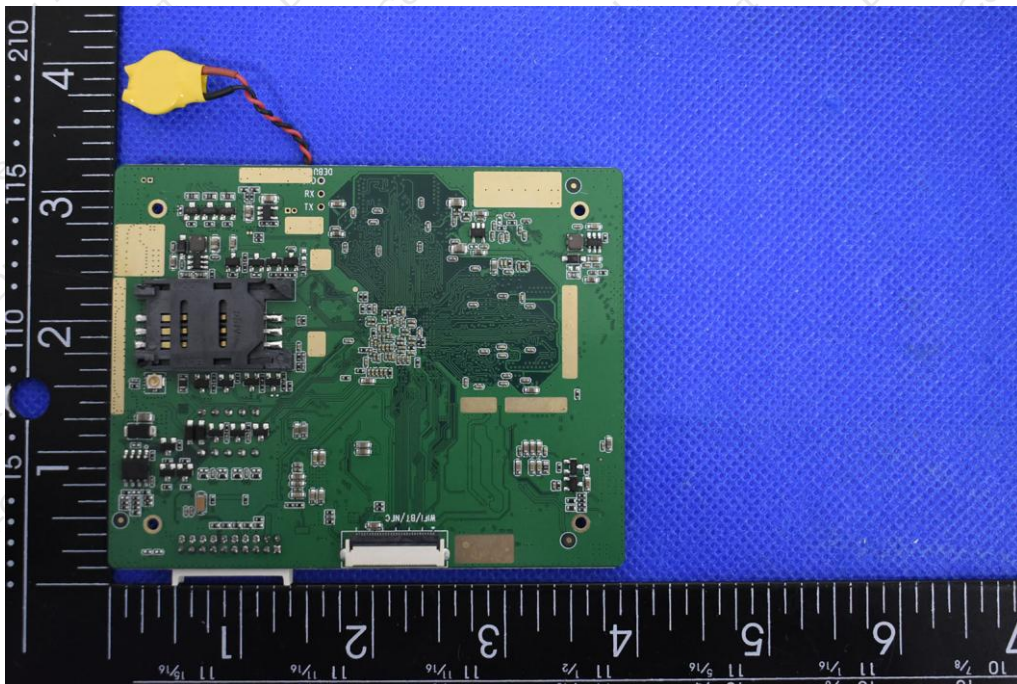
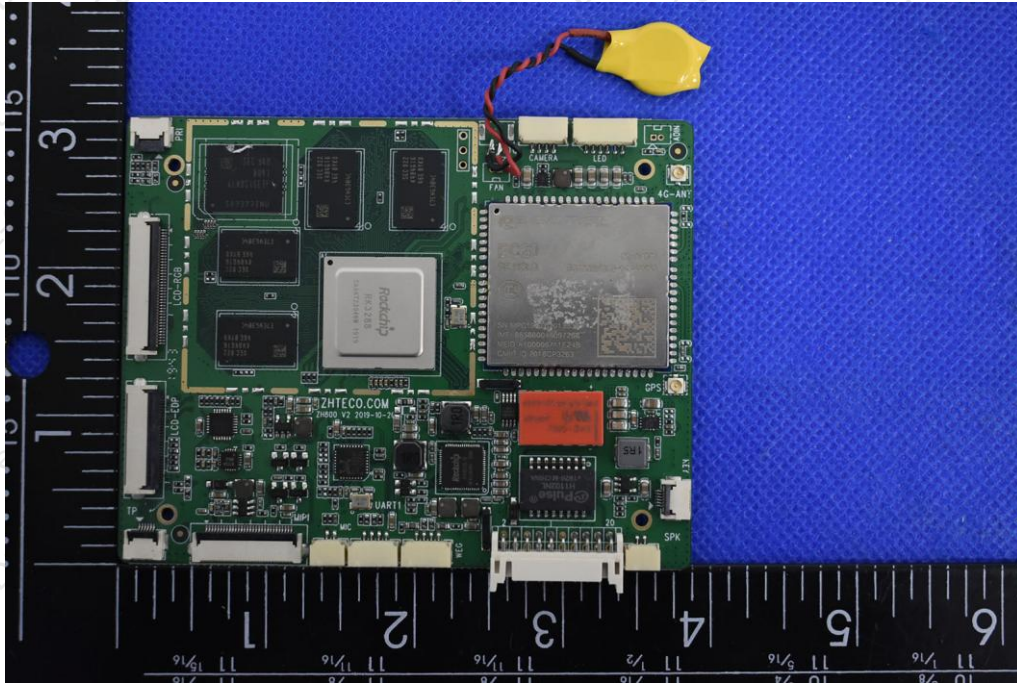

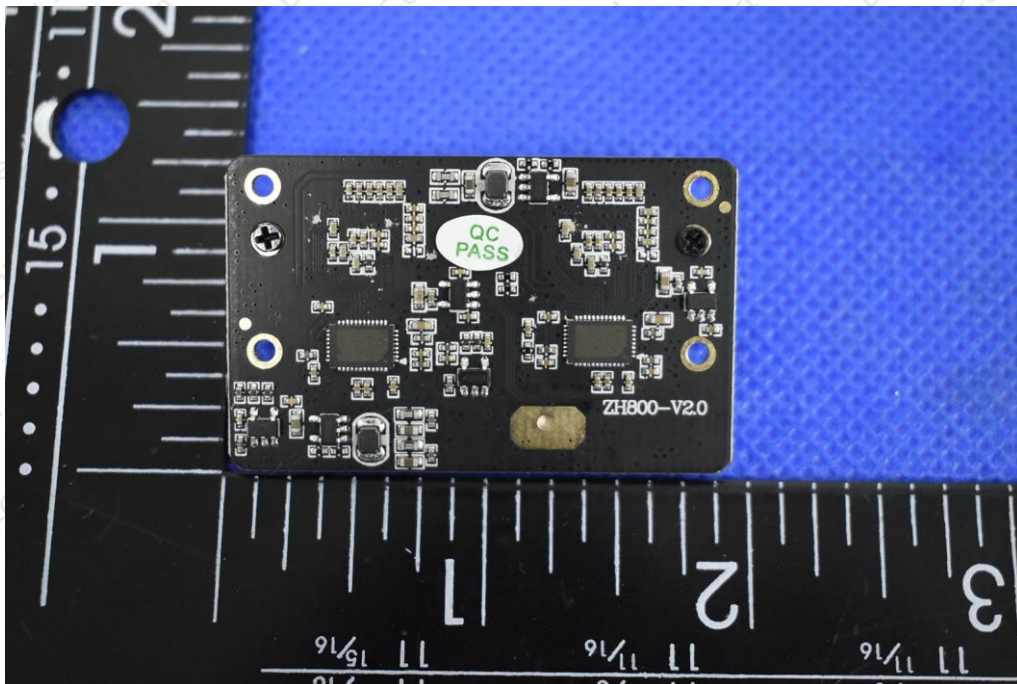
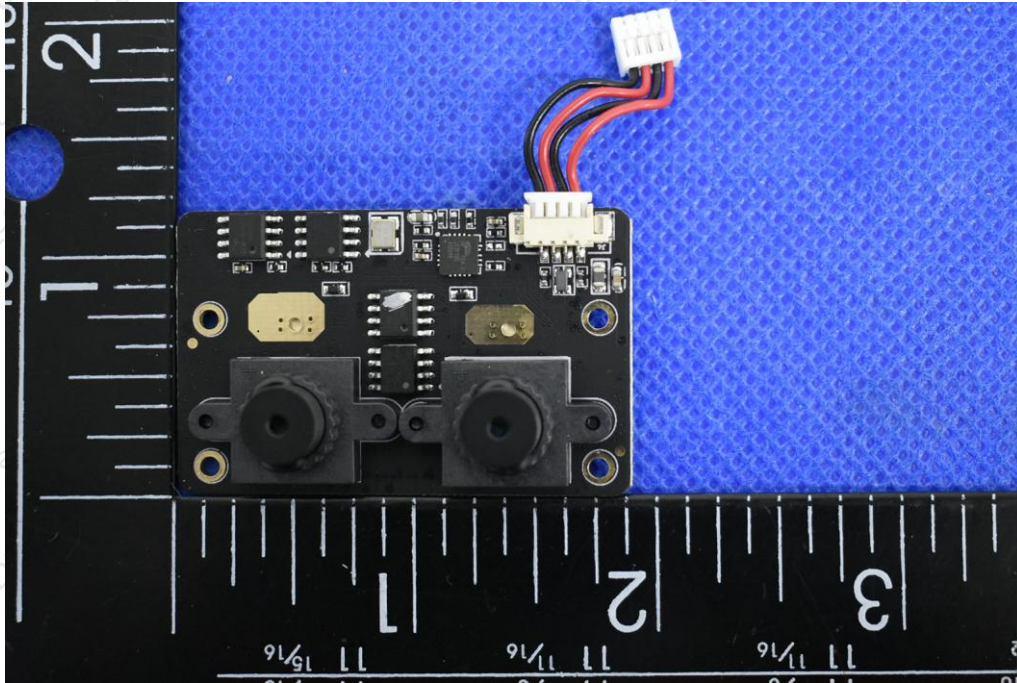

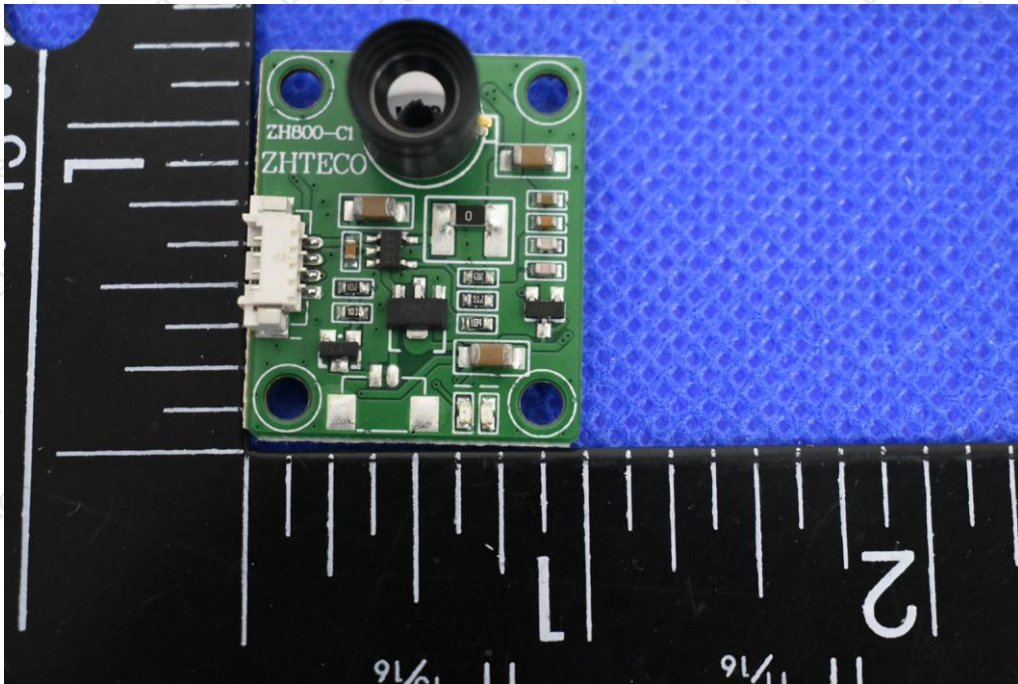
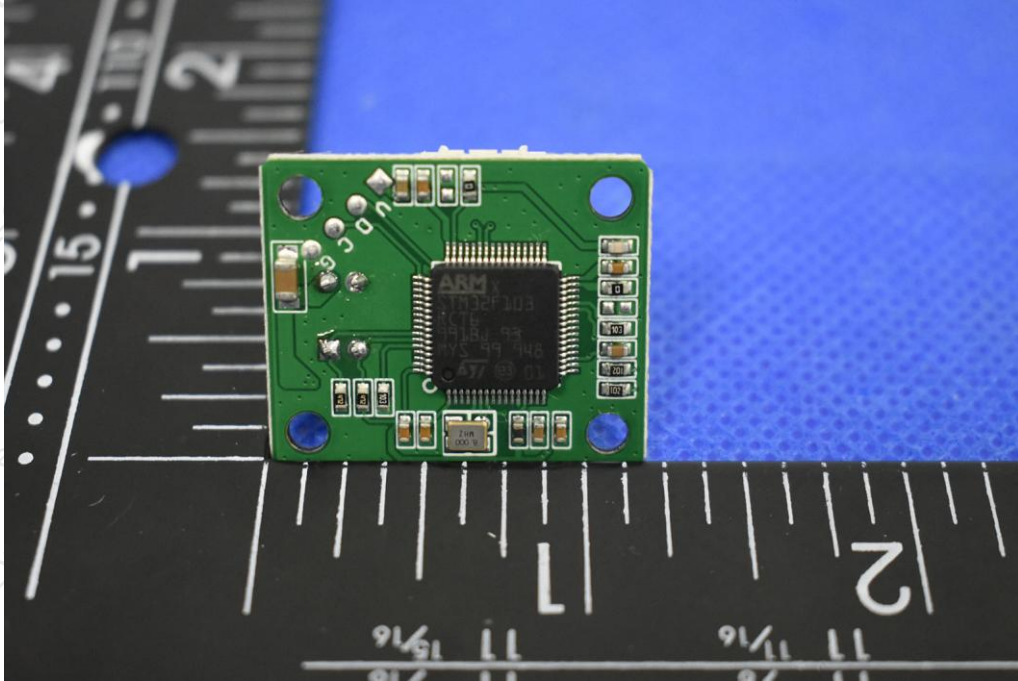

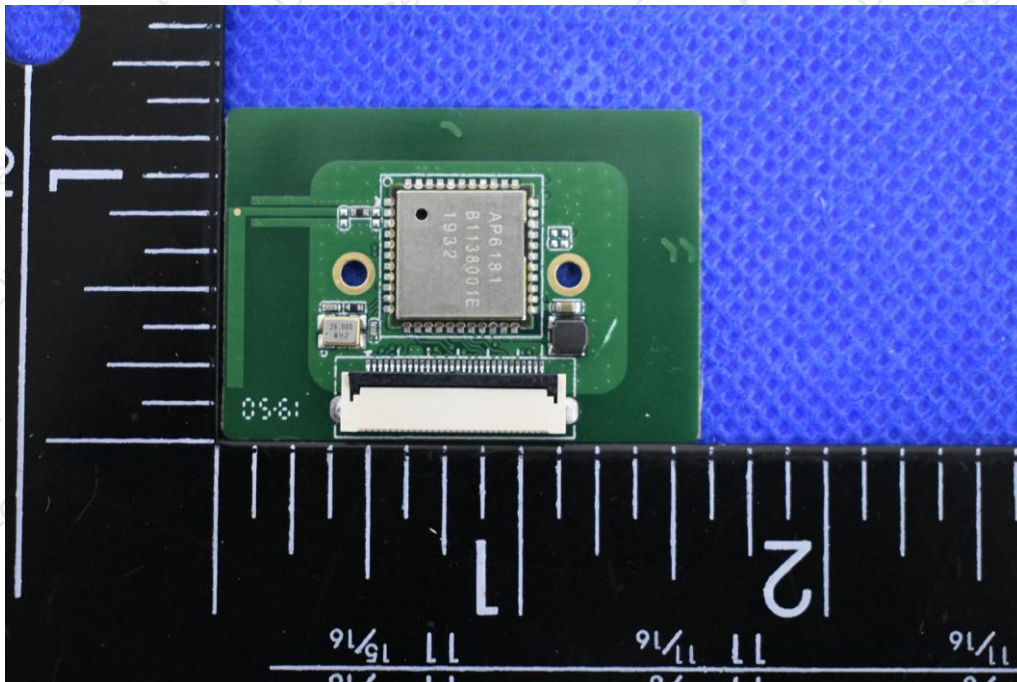
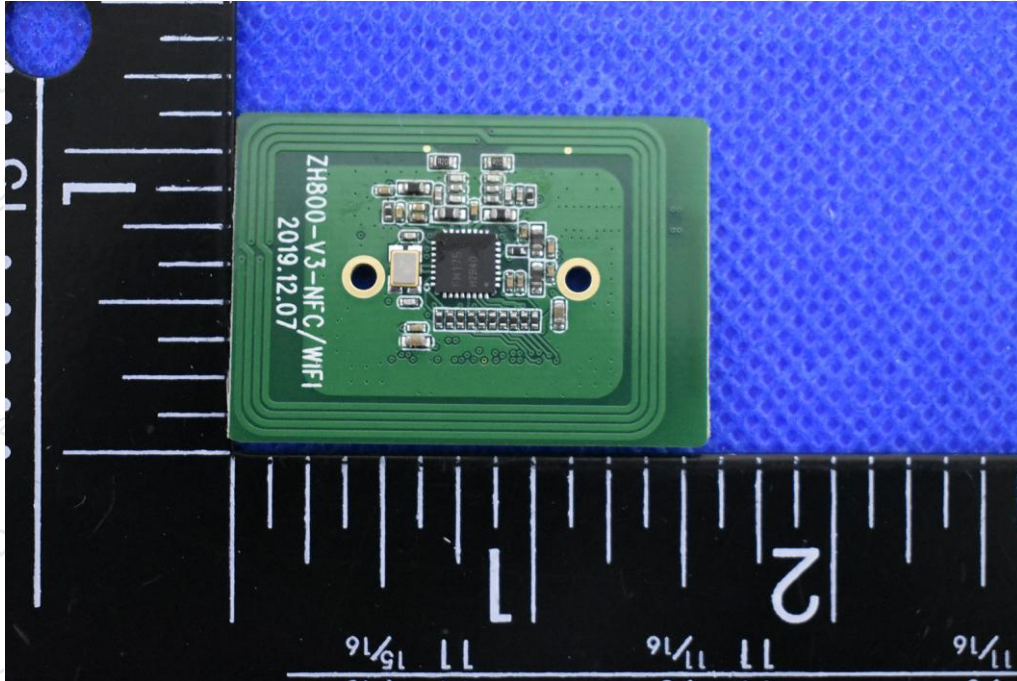

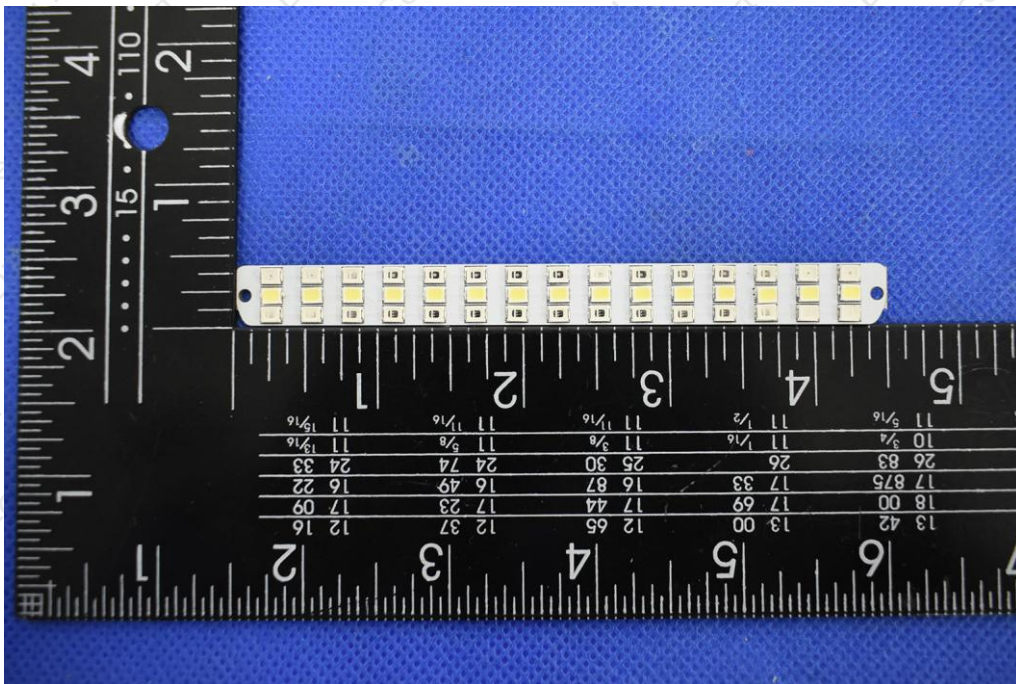
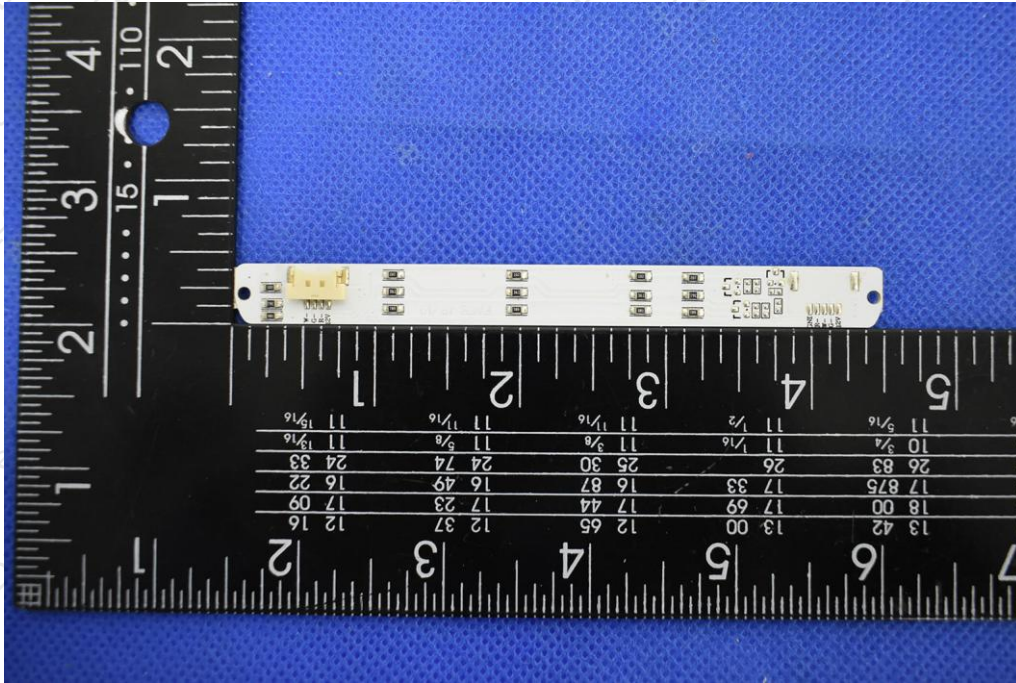

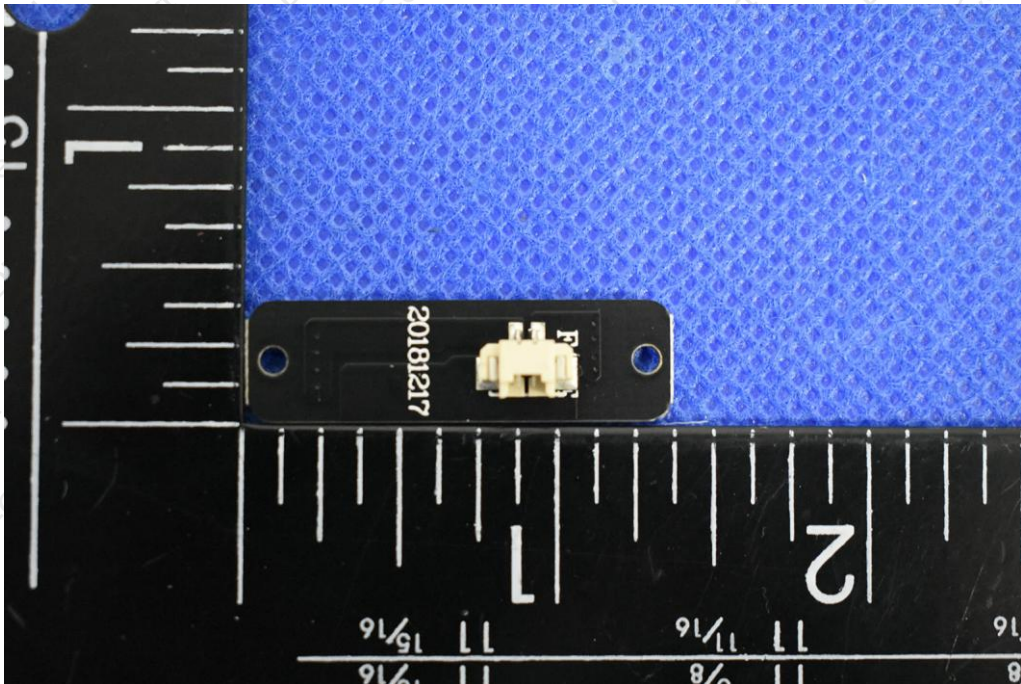
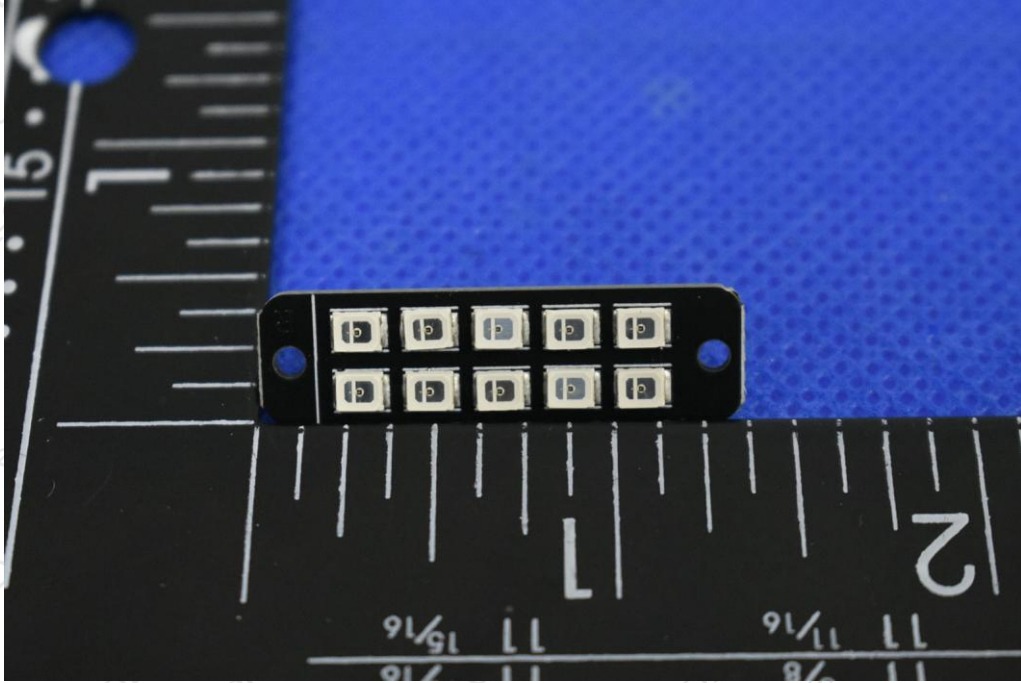

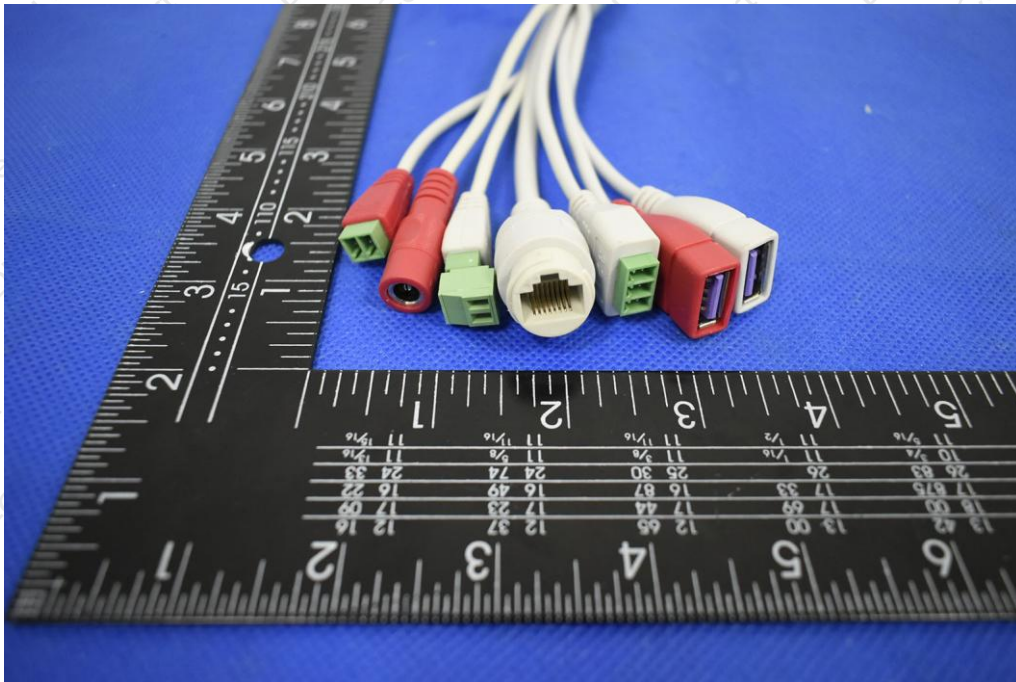
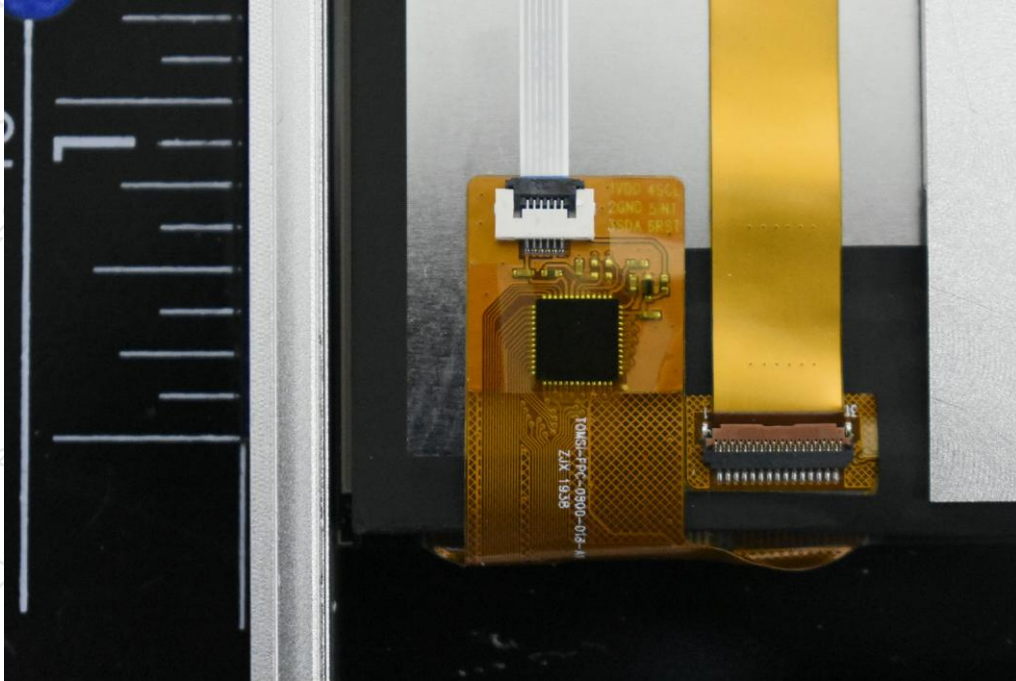



***** END OF REPORT *****